

STANDARDS

American National Standard

ANSI/NECA/BICSI 568-2006

**Standard for
Installing Commercial Building
Telecommunications Cabling**



NECA/BICSI 568-2006

Standard for

Installing Commercial Building Telecommunications Cabling

**An American
National Standard**



Published by
National Electrical
Contractors Association



Jointly developed with



NOTICE OF COPYRIGHT

This document is copyrighted by NECA

Reproduction of these documents either in hard copy or soft (including posting on the web) is prohibited without copyright permission. For copyright permission to reproduce portions of this document, please contact NECA Standards & Safety at (301) 657-3110 ext. 546, or send a fax to (301) 215-4500.

OR

National Electrical Contractors Association
3 Bethesda Metro Center, Suite 1100
Bethesda, Maryland 20814
(301) 657-3110

Organizations may obtain permission to reproduce a limited number of copies by entering into a license agreement. For information, contact:

Global Engineering Documents
15 Iverness Way East
Englewood, CO 80112-5704 or call
1-800-854-7179 (USA and Canada)
(303) 397-7956 (International)

Table of Contents

- Foreword**v

- 1. Scope**1
- 1.1 Products and Applications Included1
- 1.2 Regulatory and Other Requirements1
- 1.3 Local Code Requirements2

- 2. Definitions, Acronyms, Abbreviations, and Units of Measure** 3
- 2.1 Definitions3
- 2.2 Acronyms, Abbreviations, and Units of Measure13

- 3. Support Structures**14
- 3.1 General14
- 3.2 Pathways14
 - 3.2.1 General14
 - 3.2.2 Cable trays14
 - 3.2.3 D-rings and mushrooms16
 - 3.2.4 Conduits16
 - 3.2.5 Supports18
 - 3.2.6 Surface raceway18
- 3.3 Spaces18
 - 3.3.1 Plywood18
 - 3.3.2 Equipment racks19
 - 3.3.3 Floor-mounted cabinets20
 - 3.3.4 Wall-mounted equipment racks and cabinets20
- 3.4 Bonding Infrastructure20
 - 3.4.1 General20
 - 3.4.2 Bonding conductor20
- 3.5 Installing Cable Support Systems20
 - 3.5.1 General20

- 4. Pulling Cable**24
- 4.1 General24
- 4.2 Cable Pulling Setup24
 - 4.2.1 Overview24
 - 4.2.2 Pulling horizontal cable in conduit25
 - 4.2.3 Pulling horizontal cable in open ceiling25
 - 4.2.4 Pulling backbone in vertical pathway—from top down25
 - 4.2.5 Pulling backbone in vertical pathway—from bottom up25

4.2.6	Pulling backbone—horizontal	25
4.2.7	Cable pulling precautions	25
5.	Firestopping	26
5.1	General	26
5.2	Typical Installations	27
5.2.1	Sealing a floor penetration with putty	27
5.2.2	Sealing an outlet box with putty	28
5.2.3	Steps—restore penetrations (general)	29
6.	Cable Terminations	31
6.1	General	31
6.2	Pre-termination Functions	31
6.3	Copper IDC Termination	31
6.3.1	General	31
6.3.2	Steps—IDC termination	32
6.4	Fiber Termination	33
6.5	Copper Cable Splicing	33
6.6	Optical Fiber Cable Splicing	34
7.	Installation Verification	35
Annex A:	Field Test Requirements	36
A.1	General	36
A.2	100-Ohm Balanced UTP Cabling	36
A.2.1	Test instruments	36
A.2.2	Performance parameters	36
A.2.3	Permanent link test configuration	36
A.2.4	Channel test configuration	37
A.2.5	Backbone and other cabling test configuration	37
A.3	Optical Fiber Cabling	37
A.3.1	Test instruments	38
A.3.2	Performance parameters	38
A.3.3	Cabling test configuration	38
A.3.4	Verifying test jumper quality	38
Annex B:	Reference Standards	41
List of Tables		
Table 1	Minimum conduit bend radius	17
Table 2	Minimum separation distances from possible sources of EMI exceeding 5kVA	22
Table 3	Preferred color coding scheme for premises cable jackets (ANSI/TIA-598-C)	24
Table 4	Color-code chart up to 600 pair	32
Table 5	Optical fiber color code chart (ANSI/TIA-598-C)	33
Table 6	Acceptable mandrel diameters for common mulitmode cable types (five wraps)	38

List of Figures

Figure 1	Example of structured cable system	1
Figure 2	Suspended cable tray (tubular)	14
Figure 3	Wall bracket support (tubular)	15
Figure 4	Mesh cable tray	15
Figure 5	Elevation view of cable tray installed on the rear wall of a telecommunications room	15
Figure 6	Typical backboard layout using distribution-rings	16
Figure 7	Spools (Mushrooms)	16
Figure 8	Plywood installation over drywall using toggle bolts	19
Figure 9	Tear off putty	27
Figure 10	Building bottom of penetration seal	27
Figure 11	Filling the penetration	27
Figure 12	Building top on penetration	28
Figure 13	Overlap the pad on outlet box	28
Figure 14	Second pad of putty on outlet box	28
Figure 15	Joining the pads on outlet box	28
Figure 16	Conduit penetration through masonry wall or floor	29
Figure 17	Fire seal of drywall	29
Figure 18	Fire seal cable tray penetration	30
Figure 19	Wiring schemes	31
Figure 20	Shield bond connector and braid	34
Figure 21	In-line splice configuration	34
Figure 22	Foldback splice configuration	34
Figure 23	Permanent link test configuration	36
Figure 24	Channel test configuration	37
Figure 25	Example of OLTS reference measurement (P1) with one test jumper (multimode)	39
Figure 26	Example of a measurement (P2) when verifying OLTS test jumpers (multimode)	39
Figure 27	Example of OLTS reference measurement (P1) with one test jumper (multimode)	40
Figure 28	Example of a multimode link attenuation measurement (P2)	40

<This page intentionally left blank>

(This foreword is not a part of the standard)

Foreword

National Electrical Installation Standards[™] (*NEIS*[®]) are designed to improve communication among specifiers, purchasers, and suppliers of electrical construction services. They define a minimum baseline of quality and workmanship for installing electrical products and systems. *NEIS* are intended to be referenced in contract documents for electrical construction projects. The following language is recommended:

Commercial building telecommunications cabling shall be installed in accordance with NECA/BICSI 568-2006, *Standard for Installing Commercial Building Telecommunications Cabling* (ANSI).

In 1998, a large number of companies representing the telecommunications and electrical industry expressed concern over the lack of a standard for installation of telecommunications premises cabling systems. The National Electrical Contractors Association (NECA) asked BICSI[®], A Telecommunications Association, to jointly undertake the task of developing the required standard. BICSI accepted the task and the project was assigned to BICSI/NECA Joint Technical Committee 1 for the Development of Telecommunications Cabling Installation Guidelines.

BICSI and NECA standards documents are developed within the Technical Committees of BICSI and NECA. Members of these committees serve voluntarily and without compensation. The companies they represent are not necessarily members of BICSI or NECA. The standards developed within these committees represent a consensus of the broad expertise on the subject. This expertise comes from within BICSI and NECA as well as from those out-

side that have an expressed interest. The viewpoint expressed at the time this standard was approved was from the contributors' experience and the state of the art at that time. Users are encouraged to confirm that they have the latest revision of the standard.

BICSI/NECA/JTC1 reviews its standards, at the minimum, every 5 years. At that time standards are reaffirmed, rescinded or revised according to the submitted updates. Updates to be included in the next revision should be sent to the committee chair or to BICSI/NECA/JTC1.

This standard has been prepared by BICSI/NECA/JTC1 under the joint jurisdiction of BICSI and NECA and approved by consensus ballot.

Use of *NEIS* is voluntary, and neither NECA nor BICSI assume any obligation or liability to users of this publication. Existence of a standard shall not preclude any member or nonmember of either organization from specifying or using alternate construction methods permitted by applicable regulations.

This publication is intended to comply with the edition of the *National Electrical Code*[®] (NEC[®]) in effect at the time of publication. Because they are quality standards, *NEIS* may in some cases go beyond the minimum safety requirements of the NEC. It is the responsibility of users of this publication to comply with state and local regulatory codes when installing electrical products and systems.

Suggestions for revisions and improvements to this standard are welcome. They should be addressed to:

NECA Standards & Safety
3 Bethesda Metro Center, Suite 1100
Bethesda, MD 20814
(301) 657-3110 telephone
(301) 215-4500 fax
www.neca-neis.org
neis@necanet.org

To purchase *National Electrical Installation Standards* contact the NECA Order Desk at (301) 215-4504 tel, (301) 215-4500 fax, or orderdesk@necanet.org. *NEIS* can also be purchased in .pdf download format at www.neca-neis.org/standards.

Copyright © 2006, National Electrical Contractors Association. All rights reserved. Unauthorized reproduction prohibited.

National Electrical Installation Standards and *NEIS* are trademarks of the National Electrical Contractors Association. BICSI is a registered trademark of BICSI—A Telecommunications Association, Tampa, FL. National Electrical Code and NEC are registered trademarks of the National Fire Protection Association, Quincy, MA.

Revision History	
NECA/BICSI 568-2001	10/2001
NECA/BICSI 568-2006	06/2006

1. Scope

1.1 Products and Applications Included

A structured cabling system is a complete collective configuration of cabling and associated hardware on a premises which, when installed, provides a comprehensive telecommunications infrastructure. This infrastructure is intended to support a wide range of telecommunications services such as telephone and computer networks. Figure 1 illustrates an example of components that comprise a structured cabling system.

This Standard describes minimum requirements and procedures for installing the infrastructure for telecommunications including balanced twisted pair copper cabling and optical fiber cabling that transport telecommunications signals (e.g., voice, data, video). Installers should always follow applicable codes and manufacturers' instructions. This Standard is intended to be used in describing a "neat and workmanlike manner" as referenced by ANSI/NFPA 70, the National Electrical Code (NEC).

1.2 Regulatory and Other Requirements

a) All information in this publication is intended to conform to the National Electrical Safety Code (ANSI/IEEE C2) and National Electrical Code (ANSI/NFPA 70). Installers should always follow the NESC, NEC, applicable state and local codes, manufacturer's instructions, and contract documents when installing telecommunications cabling.

b) Only qualified persons familiar with telecommunications cabling should perform the work described in this publication. It is recommended that all work be performed in accordance with NFPA 70E, *Standard for the Electrical Safety in the Workplace*.

c) General requirements for installing electrical products and systems are described in the latest version of NECA 1, *Standard Practices for Good Workmanship in Electrical Contracting* (ANSI). Other *NEIS* provide additional guidance for installing particular types of electrical products and systems. A complete list of *NEIS* is provided in Annex B. The installation should follow the NEC, applicable state

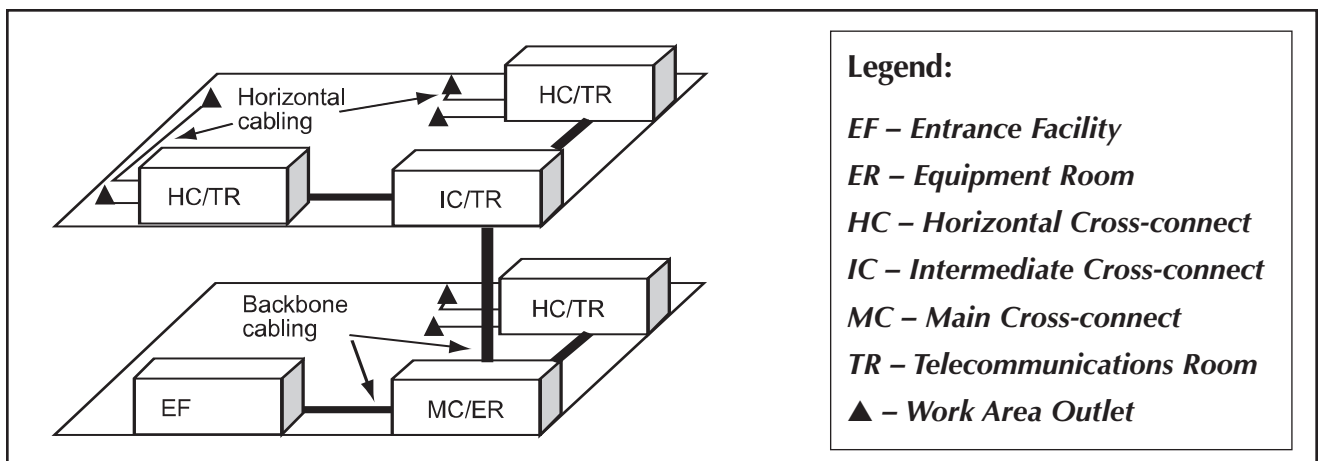

Figure 1—Example of structured cabling system

and local codes, and manufacturers' instructions for the installation of electrical and telecommunications products and systems.

d) Information within this standard is intended to comply with the following standards.

- ANSI/NFPA 70-2005; *National Electrical Code*
- ANSI/TIA 455-78-B-2002; *Optical Fibres – Part 1-40: Measurement Methods and Test Procedures – Attenuation*
- ANSI/TIA 598-C-2005; *Optical Fiber Cable Color Coding*
- ANSI/TIA 526-7-1998; *Optical Power Loss Measurements Of Installed Single-mode Fiber Cable Plant*
- ANSI/TIA 526-14-A-1998; *Optical Power Loss Measurements Of Installed Multimode Fiber Cable Plant*
- ANSI/TIA 568-B Series-2001; *Commercial Building Telecommunications Cabling Standard*
- ANSI/TIA 606-A-2002; *Administration Standard for the Telecommunications Infrastructure of Commercial Buildings*
- ANSI/J-STD 607-A-2002; *Commercial Building Grounding (Earthing) and Bonding Requirements for Telecommunications*
- ANSI/TIA 569-B-2004; *Commercial Building Standard for Telecommunications Pathways and Spaces*
- TIA/TSB 140-2004; *Additional Guidelines for Field-Testing Length, Loss and Polarity of Optical Fiber Cabling Systems*

erning authority. Most of the code requirements for the job should be included in the scope of work documents. The installer should never take this information for granted, since the telecommunications contractor is fully responsible for all work done on the project.

If no code has been adopted locally, consult with the fire marshal's office to determine what agency is responsible for that geographic area and what codes are in effect. Do not depend on other installers, contractors, or even company personnel in making these determinations.

1.3 Local code requirements

Local code requirements shall be followed. Always review the local code requirements with the local AHJ before proceeding with the installation. This includes reviewing what code and edition is adopted, and what, if any, exceptions to the code are adopted by the gov-

2. Definitions, Acronyms, Abbreviations, and Units of Measure

2.1 Definitions

For the purposes of this standard, the following definitions apply:

Administration The method for labeling, documentation, and usage needed to implement moves, additions, and changes of the telecommunications infrastructure.

Alien Crosstalk A measure of the unwanted signal coupling between adjacent cabling or components.

All-Thread-Rod A straight section of round rod stock that has threads installed over its entire length. Also known as a threaded rod. American wire gauge:

Anchor

1. A fastening device.
2. In an outside plant environment, a device made up of a single plate or series of flat plates and combined with a rod having a connecting eye.

Architectural Structures Walls, floors, floor/ceilings, and roof/ceilings that are load bearing.

As-built The documentation of measurements, location, and quantities of material work performed. May be in the form of marked up documents or other work order forms.

Attenuation The decrease in magnitude of transmission signal strength between points, expressed as the ratio of output to input. Measured in decibels (dB), usually at a specific frequency for copper or wavelength for optical fiber, the signal strength may be power or voltage.

Authority Having Jurisdiction (AHJ) The entities responsible for interpretation and enforcement of local building and electrical codes.

Backboard A panel (e.g., wood, metal) used for mounting connecting hardware and equipment.

Backbone

1. A facility (e.g., pathway, cable, conductors) between any of the following spaces: telecommunications rooms, telecommunications enclosures, common telecommunications rooms, floor-serving terminals, entrance facilities, equipment rooms, and common equipment rooms.
2. In a data center, a facility (e.g., pathway, cable, conductors) between any of the following spaces: entrance rooms or spaces, main distribution areas, horizontal distribution areas, and telecommunications rooms.

Backbone Cable	<i>See Backbone and Backbone Cabling.</i>	Bonding	The permanent joining of metallic parts to form an electrically conductive path that will ensure electrical continuity and the capacity to conduct safely any current likely to be imposed.
Backbone Cabling	Cable and connecting hardware that provides interconnections between telecommunications rooms, equipment rooms, and entrance facilities. <i>See backbone.</i>	Bonding Conductor	A conductor used specifically for the purpose of bonding.
Backbone Pathway	The portion of the pathway system that permits the placing of backbone cables between the entrance location and all cross-connect points within a building and between buildings.	Bonding Conductor for Telecommunications	A conductor that interconnects the building's service equipment (power) ground to the telecommunications grounding system.
Bandwidth	<ol style="list-style-type: none"> 1. A range of frequencies available for signaling expressed in hertz. 2. The information handling capability of a medium, expressed in units of frequency (hertz). 	Braid	A group of non-insulated conductors interwoven to surround one or more insulated conductors.
Beam Clamp	A device attached to a building structure to hold cable supports or equipment.	Bullwheel	A large wheel used to maintain an arc when feeding large cables into a backbone pathway.
Bend Radius	The radius of curvature that a media can bend without signal degradation.	Bundle	<ol style="list-style-type: none"> 1. Many individual optical fibers contained within a single jacket or buffer tube. Also, a group of buffered optical fibers distinguished in some fashion from another group in the same cable core. 2. Also used to indicate time and common handling of multiple cables routed together.
Binder Group	One of two or more bound copper pairs or optical fiber strands within a cable.	Cabinet	A container that may enclose connection devices, terminations, apparatus, wiring, and equipment.
Blueprint	A reproduction of an architectural plan and/or technical drawing that provides details of a construction project or an existing structure.	Cable	An assembly of one or more insulated conductors or optical fibers within an enveloping sheath.

Cable Run	A length of installed media, which may include other components along its path.	Cabling System	A specific system of cables, equipment/patch cords, connecting hardware, and other components supplied as a single entity.
Cable Sheath	A covering over the optical fiber or conductor assembly that may include one or more metallic members, strength members, or jackets.	Channel	<ol style="list-style-type: none"> 1. The end-to-end transmission path connecting interfaces of any two pieces of application-specific equipment. Equipment cords and work area cords are included in the channel. 2. In frequency division multiplexing, a band in the frequency spectrum that is assigned to a specific logical connection. 3. In time division multiplexing, a time that is assigned to a specific logical connection.
Cable Support System	A combination of conduits, cable trays, support hooks, tie wraps, and any other hardware pieces used in a cabling installation to support cables. Cable support systems keep excess stress off the cables and may provide some mechanical protection to the cables being supported.		
Cable Termination	The connecting or termination hardware applied to the end of a cable for the purpose of facilitating connection to active or passive transmission equipment.	Channel Stock	A metallic U-shaped bar with or without evenly spaced holes. Often hung in a trapeze configuration for support of pathway systems, such as conduits and cable trays.
Cable Tray	A rigid structure for supporting, housing and protecting cables or conductors. Usually consists of one-piece solid or ventilated bottom or individual transverse members with two side rails.	Circuit	The electrical or optical path used for communications between two devices.
Cable Tree	A vertical rack with multiple arms for holding small reels of cable.	Code	A rule intended to ensure safety during the installation and use of materials, components, fixtures, systems, premises, and related subjects. Codes are typically invoked and enforced through government regulation.
Cabling	A system of cables, cords, and connecting hardware. equipment/patch cords, and connecting hardware.	Commercial Building	A building, or portion thereof, that is intended for office use.

Conduit	<ol style="list-style-type: none"> 1. A raceway of circular cross-section. 2. A structure containing one or more ducts. 	Cross-connect	A facility enabling the termination of cable elements and their inter-connection or cross-connection.
Conduit Stub-out	A short section of conduit that is installed from a receptacle box, usually in a wall, curved into an accessible ceiling space.	Cross-connection	A connection scheme between cabling runs, subsystems, and equipment using patch cords or jumpers that attach to connecting hardware on each end.
Conduit Stub-up	A short section of conduit that is installed from a receptacle box, usually in a wall, into an accessible ceiling space directly above the receptacle box.	Crossed Pairs	An error condition where physical connection of a wire or wires in a pair of wires is made to another wire or wires in yet another pair of wires generally found in the same cable.
Cone	Safety marker that is used to designate a secure off-limits area for non-workers.	Decibel	A logarithmic unit for measuring the relative voltage, power (in watts) or strength (in voltage or current) of a signal. A decibel is one tenth of a bel.
Connecting Hardware	A device, or combination of devices, used to connect two cables or cable elements.	Distribution Ring	Wire management ring shaped like the letter D for routing and supporting distribution cables and jumpers/patch cables on a backboard.
Connector	A mechanical device used to provide a means for aligning, attaching, and achieving continuity between conductors or optical fibers.	Dressing	Placing cables into a neat and symmetrical pattern for proper alignment and positioning for termination.
Consolidation Point	A location for interconnection between horizontal cables extending from building pathways and horizontal cables extending into furniture pathways.	Drywall	An interior wall construction consisting of gypsum or plasterboard.
Core	The central, light-carrying part of an optical fiber through which light pulses are transmitted.	Duct	<ol style="list-style-type: none"> 1. A single enclosed raceway for conductors, wires, or cables. See also raceway. 2. An enclosure in which air is moved. Generally part of the heating, ventilating, and air-conditioning system of a building.
Crimp	The act of clamping connectors to a cable.		

Entrance Facility (Telecommunications)	An entrance to a building for both public and private network service cables (including antennae) including the entrance point at the building wall and continuing to the entrance room or space.	Firewall	1. A continuous barrier used to prevent fire spreading from one fire zone or area to another. 2. One or more security mechanisms (hardware and/or software) designed to prevent, detect, suppress, and/or contain unauthorized access to a network.
Entrance Room (Telecommunications)	A space in which the joining of campus or building telecommunications backbone facilities takes place.	Floor Slab	1. That part of a reinforced concrete floor, which is carried on beams below. 2. A concrete mat poured on subgrade serving as a floor rather than as a structural member.
Equipment Room (Telecommunications)	An environmentally controlled centralized space for telecommunications equipment that usually houses a main or intermediate cross-connect.	Foldback Splicing	Process of folding back conductors in a splice for future maintenance or rearrangements.
Fire Retardant	Any substance added to delay the start of fire ignition or to slow the spread of flame by the burning material.	Ground	A conducting connection, whether intentional or accidental, between an electrical circuit or equipment and the earth, or to some conducting body that serves in place of earth.
Firestop	A fire-rated material, device, or assembly of parts installed in a penetration of a fire-rated barrier.	Ground Electrode	A conductor, usually a rod, pipe, or plate (or group of such conductors), in direct contact with the earth for the purpose of providing a low-impedance connection to earth.
Firestop System	A specific listed assembly consisting of the material(s) (firestop penetration seals) that fill the opening in the wall or floor assembly, and around and between any items that penetrate the wall or floor (e.g., cables, cable trays, conduit, ducts, pipes), and any termination devices (e.g., electrical outlet boxes) along with their means of support.	Grounded	Connected to earth or to some conducting body that serves in place of the earth.
		Ground Wire	<i>See bonding conductor and bonding conductor for telecommunications.</i>

Grounding System	A system of hardware and wiring that provides an electrical path from a specified location to an earth ground point.	Insulation	The dielectric material that physically separates wires and prevents conduction between them.
Horizontal Cable	Distribution media that connect the telecommunications outlet/ connector at the work area and the first piece of connecting hardware in the horizontal cross-connect.	Insulation Displacement Contact	A type of wire termination in which the insulation that is surrounding a conductor is displaced at the connection point without physically stripping the insulation from the conductor and consequently makes a gas-tight connection to the conductor.
Horizontal Cross-connect	A group of connectors (e.g., patch panel, punch-down block) that allows equipment and backbone cabling to be cross-connected with patch cords or jumpers. Floor distributor is the international equivalent term for horizontal cross-connect.	Interconnection	<ol style="list-style-type: none"> 1. A connection scheme that employs connecting hardware for the direct connection of a cable to another cable without a patch cord or jumper. 2. A type of connection in which single-port equipment connections (e.g., 4-pair and optical fiber connectors) attach to horizontal or backbone cabling by means of patch cord or jumper.
Infrastructure (Telecommunications)	A collection of those telecommunications components, excluding equipment, that together provide the basic support for the distribution of all information within a building or campus.	Intermediate Cross-connect	The connection point between a backbone cable that extends from the main cross-connect (first-level backbone) and the backbone cable from the horizontal cross-connect (second-level backbone).
In-line Splice	A splice in which cable enters one endcap and, after splicing the cable, exits the other endcap of the closure.	Jacket	The outer layer of a cable. See <i>Cable Sheath</i> .
Innerduct	A non-metallic pathway, usually circular, placed within a larger pathway.	J-hook	A supporting device for horizontal cables that is shaped like a “J.” It is attached to some building structures. Horizontal cables are laid in the opening formed by the “J” to provide support for the cables.
Insertion Loss	The signal loss resulting from the insertion of a component, or link, or channel, between a transmitter and receiver (compare “Jumper” and “Mushroom”). See <i>Attenuation</i> .		

Jumper	1. An assembly of twisted pairs without connectors, used to join telecommunications circuits/links at the cross-connect. 2. An optical fiber cable with connectors installed on both ends. See <i>Cable Assembly</i> .	Mushroom	See <i>Spool</i> .
Ladder Rack	A device similar to a cable tray but more closely resembles a single section of a ladder. It is constructed of metal with two sides affixed to horizontal cross members.	Network	A series of controllers, all connected via a telecommunications cable.
Link	A transmission path between two points, not including terminal equipment, work area cables, patch cables, and equipment cables. Can be up to 90 m (295 ft) in length for horizontal cabling.	Optical Fiber	A transmission media using a thin filament of glass or plastic to transmit pulse light signals. Its bandwidth is higher than copper and not subject to electromagnetic interference. The optical fiber consists of a central core (glass or plastic) and an outer cladding.
Local Area Network	The standard industry term for a network installation that serves a relatively small area (e.g., structured cabling installation serving a building).	Optical Fiber Cable	Cable made up of one or more strands of glass consisting of a central core and outer cladding (optical fibers), strength members, and an outer jacket.
Loss	Attenuation of a signal, usually measured in dB.	Outlet Box (Telecommunications)	A metallic or non-metallic box mounted within a floor, wall, or ceiling and used to hold telecommunications outlets/connectors or transition devices.
Main Cross-connect	The cross-connect normally located in the (main) equipment room for cross-connection and interconnection of entrance cables, first-level backbone cables, and equipment cables.	Outlet/Connector (Telecommunications)	A connecting device in the work area on which horizontal cable or outlet cable terminates.
Membrane Penetration	An opening through only one surface or side of a barrier.	Pair	1. Two insulated wires commonly joined. They can be twisted around each other or mated together as in flat cable. 2. One side circuit (two diametrically facing conductors) in a star quad.
Multimode Optical Fiber	An optical wave guide that allows many bound modes to propagate.		

Pair Count	<ol style="list-style-type: none"> 1. Indicates how many pairs of grouped conductors are in a cable. 2. The pair identification of cable and pairs serving a location. 	Reversed Pair	<p>A condition in which the conductors in a pair are terminated in the wrong sequence (i.e., tip connects to ring and ring connects to tip).</p>
Patch Cord	<p>A length of cable with connectors on both ends used to join telecommunications circuits/links at the cross-connect.</p>	Ring	<p>A means for identification of one conductor of a pair. Historically associated with the wire connected to the “ring” portion of an operator’s telephone plug. See also <i>Tip</i>.</p>
Pathway	<ol style="list-style-type: none"> 1. A sequence of connections that provides the connectivity between devices on a network or between networks on an internetwork. 2. The vertical and horizontal route of the telecommunications cable. 3. A facility for the placement of telecommunications cable. 	Scope of Work	<p>A document that provides detailed statements and descriptions of the work content for the project requirements.</p>
Premises	<p>Building, or set of buildings on common property, that are occupied by a single tenant or landlord.</p>	Screened Twisted-pair Cable	<p>A cable with one or more pairs of twisted copper conductors covered with an overall metallic shield. See <i>Foiled Twisted-pair Cable</i>.</p>
Pull	<ol style="list-style-type: none"> 1. The act of placing cable by pulling. 2. The longitudinal force acting on a pole as a result of horizontal loading. 	Sheath	<p>See <i>Cable Sheath</i>.</p>
Raceway	<p>Any enclosed channel designed for holding wires or cables.</p>	Shield	<p>A metallic layer (e.g., copper braids, metal foils, solid tubing) placed around a conductor or group of conductors.</p>
Rack	<p>See <i>Cable Rack</i>.</p>	Short	<p>An unintentional low-resistance connection between two conducting materials.</p>
Reel Brake	<p>A device used to control the rate of removal of a cable from a cable reel.</p>	Single-mode Optical Fiber	<p>Optical fiber with a relatively small core diameter of 8–9 micron (micrometers) and a cladding diameter of 125 micron; lightwave propagation is restricted to a single path, or mode, in single-mode optical fiber.</p>

Sleeve	An opening, usually circular, through the wall, ceiling, or floor to allow the passage of cables.	Standard	A collection of requirements that encompass properties of components and systems that are intended to ensure an accepted degree of functionality and longevity.
Slot	An opening through a wall, floor, or ceiling usually rectangular, to allow the passage of cables.	Stub-out	See <i>Conduit Stub-out</i> .
Space (Telecommunications)	An area used for housing the installation and termination of telecommunications equipment and cable.	Stub-up	See <i>Conduit Stub-up</i> .
Splice	<ol style="list-style-type: none"> 1. A joining of conductors in a splice closure, meant to be permanent. 2. A device that joins conducting or transmitting media. 	Suspended Ceiling	A ceiling that creates an area or space between the ceiling material and the building structure above.
Splice Case	A metal or plastic housing with a semicylindrical cavity used in identical pairs to clamp around a cable splice to provide a closure.	Telecommunications	Any transmission, emission, and reception of signs, signals, writings, images, and sounds; that is, information of any nature by cable, radio, optical, or other electromagnetic systems.
Splice Closure	A device used to protect a splice. See <i>Splice Case</i> .	Telecommunications Enclosure	A case or housing for telecommunications equipment, cable terminations, and cross-connect cabling.
Split Pair	Transposition of two conductors of separate pairs.	Telecommunications Entrance Facility	See <i>Entrance Facility (Telecommunications)</i> .
Spool	<ol style="list-style-type: none"> 1. A combination of hardware and software commonly used by print servers to redirect requests destined for a printer. 2. Cylindrical containers of cable. See cable reel. 3. A cylindrical guide, typically used for routing jumpers, cross-connects, and patch cords. 	Telecommunications Entrance Room	See <i>Entrance Room (Telecommunications)</i> .
		Telecommunications Equipment Room	See <i>Equipment Room (Telecommunications)</i> .
		Telecommunications Grounding Busbar	A common point of connection for telecommunications system and equipment bonding to ground; located in the telecommunications room or equipment room.

Telecommunications Main Grounding Busbar	A busbar placed in a convenient and accessible location and bonded, by means of the bonding conductor for telecommunications, to the building service equipment (power) ground.	Underfloor Raceway	A pathway placed within the floor and from which wires and cables emerge to a specific floor area.
Telecommunications Outlet	See <i>Outlet/Connector (Telecommunications)</i> .	Unshielded Twisted-pair Cable	Cable containing one or more pairs of twisted copper without metallic shielding. The entire assembly is covered with an insulating sheath (cable jacket).
Telecommunications Room	An enclosed space for housing telecommunications equipment, cable terminations, and cross-connects. The room is the recognized cross-connect between the backbone cable and horizontal cabling.	Volt (V)	A unit of electromotive force or potential difference that will cause a current of one ampere to flow through a resistance of one ohm.
Tie Wrap	Plastic or hook and loop strip used for binding and dressing cable.	Wavelength	The distance between two points in the same phase in consecutive cycles measured in the direction of propagation.
Tip	A means for identification of one conductor of a pair. Historically, associated with the wire connected to the tip portion of an operator's telephone plug. See <i>Ring</i> .	Wire	An individually insulated solid or stranded metallic conductor.
Trapeze	A support device using threaded rod and channel stock.	Wireway	An enclosed pathway for cables.
Twisted-pair	Two individually insulated copper wires physically twisted together to form a balanced pair.	Work Area (Workstation)	A building space where the occupants interact with telecommunications terminal equipment.
Twisted-pair Cable	A multiconductor cable comprising two or more copper conductors twisted in a manner designed to cancel electrical interference. Also called <i>balanced twisted-pair cable</i> .	Work Area Outlet	A connecting device for termination of horizontal media. See also telecommunications outlet/connector.

2.2 Acronyms, abbreviations and units of measure

NECA	National Electrical Contractors Association
NESC	National Electrical Safety Code
NFPA	National Fire Protection Association
OLTS	optical loss test set
OTDR	optical time domain reflectometer
RMC	rigid metal conduit
ScTP	screened twisted-pair
TGB	telecommunications grounding busbar
TIA	Telecommunications Industry Association
TMGB	telecommunications main grounding busbar
TR	telecommunications room
TSB	Telecommunications Systems Bulletin
UTP	unshielded twisted-pair
AHJ	Authority Having Jurisdiction
ATR	all-threaded-rod
CPR	coupled power ratio
dB	decibel
dBm	decibel milliwatt
EF	entrance facility
EMI	electromagnetic interference
EMT	electrical metallic tubing
ER	equipment room
ft	feet, foot
HC	horizontal cross-connect
HVAC	heating, ventilation, and air conditioning
IC	intermediate cross-connect
IDC	insulation displacement contact
IMC	intermediate metal conduit
in	inch
km	kilometer
kVA	kilovolt amp
m	meter
µm	micron; one millionth of a meter (0.000001 meter); also called <i>micrometer</i>
MC	main cross-connect
MHz	megahertz
mm	millimeter
NEC	National Electrical Code

3. Support Structures

3.1 General

Support structures are necessary to allow installation of telecommunications wire, cable, connecting hardware, and associated apparatus. These structures comprise components such as equipment racks, cabinets, distribution rings, hangers, J hooks, plywood backboard, cable trays, conduits, slots, sleeves, and their associated hardware.

3.2 Pathways

3.2.1 General

When installing pathways, it is important to ensure that the route for the pathways are clear of obstructions, such as heating, ventilation, and air conditioning HVAC ducts, large pipes, and structural beams within the building. Where fire barriers are penetrated, they shall be firestopped to maintain the fire rating of the barrier.

Determine and locate the entire route of a pathway before installation of supports. The route shall be surveyed prior to installation to ensure that obstacles are avoided. For example, if a wall penetration cannot be established, then the work done to install the support hardware may have to be repeated or modified to get to another location. Penetrations through fire rated walls and floors should be accomplished before installing the hangers, clamps, and trapezes. Once the pathway and cables are installed, firestop the penetrations per local code requirements.

3.2.2 Cable trays

This subclause addresses the installation of a cable tray within a telecommunications room (TR), equipment room (ER) or entrance facility (EF). However, the principles involved can be applied to installing

cable trays between telecommunications spaces (e.g., TR, ER, EF) and as horizontal or backbone pathways.

Cable trays may be installed on single or multiple levels. Corners and changes in horizontal plane are accomplished by using sections of cable tray cut from standard stock and connected together with manufacturer specified hardware. The connecting hardware permits all angles, both vertical and horizontal, to be accommodated over the entire route of the cable tray.

Cable tray shall be wall mounted or supported by the building structure from above using threaded rods (ATR) and manufacturer specified attachments. ATR shall be installed using properly sized anchors and correct attachment hardware. Select the ATR to support the maximum load for which the cable tray is designed. Figure 2 illustrates a tubular cable tray that is suspended from a ceiling using ATR.

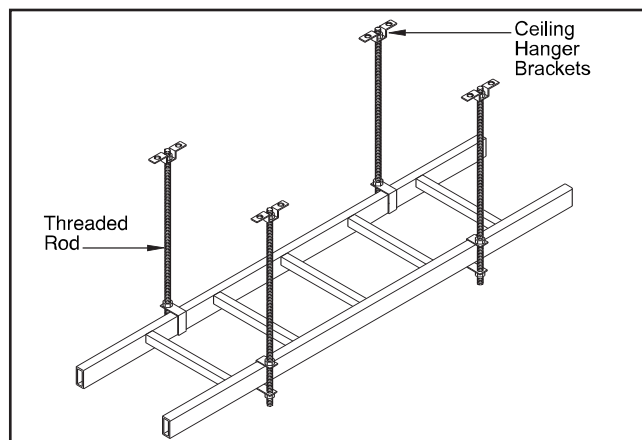

Figure 2—Suspended cable tray (tubular)

Wall mounted support brackets (see Figure 3, next page) may be used to support cable tray. Where appropriate, wall bracket supports are installed on a

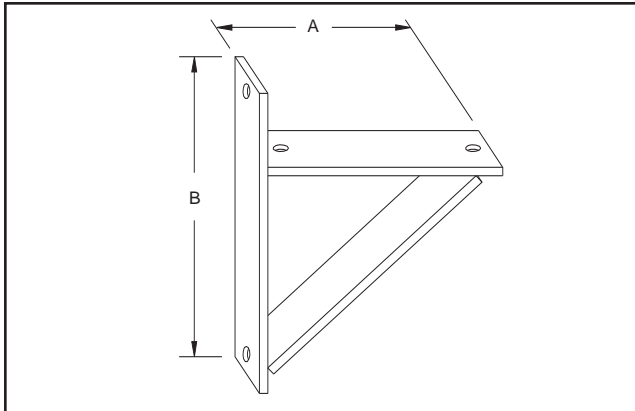

Figure 3—Wall bracket support (tubular)

wall along the route of the cable tray. The number of brackets and specific spacing interval is dependent upon the rated load the cable tray must support. Supporting attachments shall be made on a cable tray not more than 610 mm (24 in) from the ends, and at joints between two sections. Additional supports are also required every 1.5 m (5 ft) thereafter. Anchors to attach the brackets shall be sized to support the rated load of the cable tray.

Installation of mesh cable tray (see Figure 4) is accomplished by using light hand tools, power drills, and an offset blade bolt cutter. Unlike traditional cable trays, this system can be formed to adjust to changes in elevation and horizontal direction with-

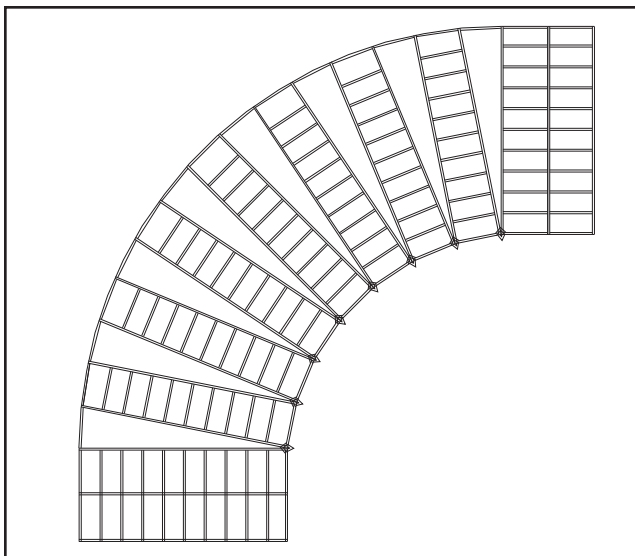

Figure 4—Mesh cable tray

out the need for application specific adapters. Corners and changes in horizontal level are accomplished by selective cutting of the mesh in the cable tray at specific points using bolt cutters and connecting the points cut together by means of manufacturer specified attachment hardware.

Cable retaining posts are available in 150 to 300 mm (6 to 12 in) lengths to allow additional cables to be installed to a depth exceeding that of the cable tray. Without these devices the cable would not be confined by the edges of the cable tray and may fall from the tray. The load rating of the cable tray and support elements shall not be exceeded by the addition of cables to this pathway.

3.2.2.1 Installation practices

Cable tray is installed from one wall to the opposite wall in a telecommunications room using angled wall supports to secure the cable tray at each end, and by wall bracket supports in the middle (see Figure 5). Another choice to support the cable tray is by using ATR attached to the building structure above.

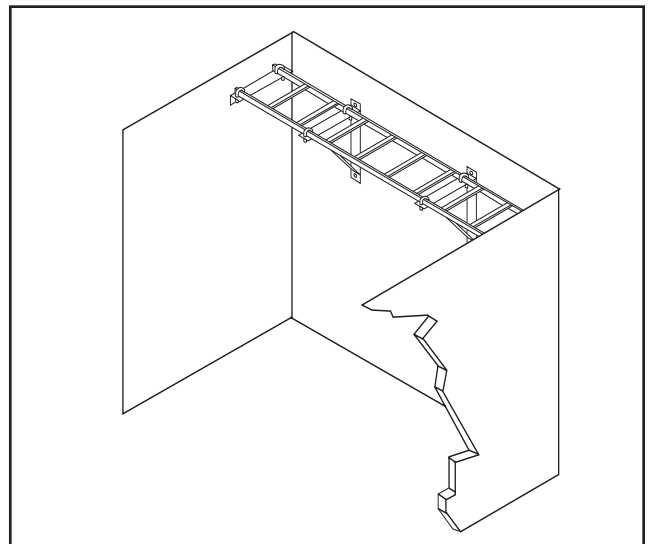

Figure 5—Elevation view of cable tray installed on the rear wall of a telecommunications room

When installing cable trays, maintain a minimum of 300 mm (12 in) above the tray and 75 mm (3 in) between the tray and the ceiling tile.

3.2.3 Distribution rings and spools (mushrooms)

Distribution rings and half-distribution-rings are used to support small bundles of cables as they route from one termination point on the plywood backboard to another. However, they should not be substituted for a cable tray. Spools are typically used for cross-connect routing.

Distribution-rings are available in many sizes, shapes, materials, and colors. Figure 6 illustrates the use of metal distribution-rings.

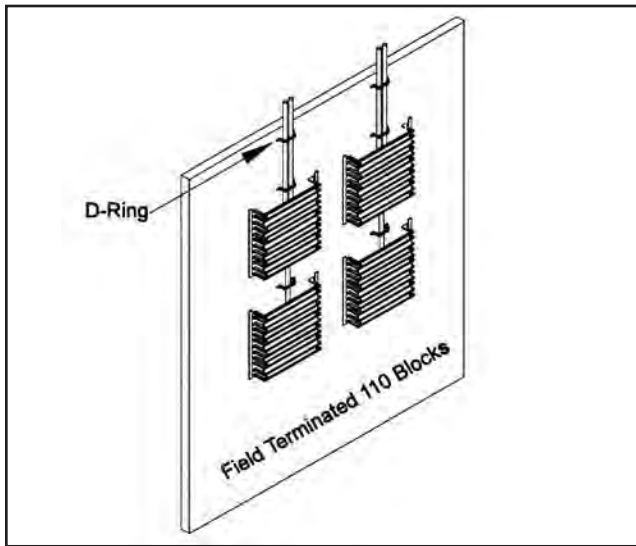

Figure 6—Typical backboard layout using distribution-rings

Spools (see Figure 7) are constructed of plastic and contain a center-mounted screw for attachment to

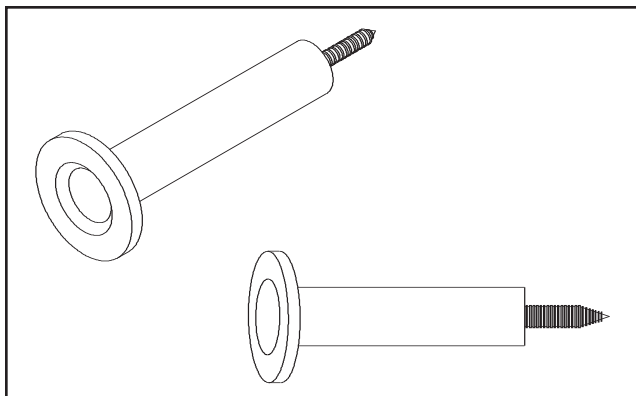

Figure 7—Spools (Mushrooms)

plywood backboards. They are also available with threaded bolts for installation on equipment racks.

3.2.4 Conduits

3.2.4.1 General

Conduit installations should be designed to be parallel or perpendicular to permanent walls of the building. When installing conduits in a ceiling, a minimum of 75 mm (3 in) vertical clearance is required above the ceiling tiles. The telecommunications designer’s drawings should indicate the location of each conduit and where they terminate in the room.

3.2.4.2 Segment limits

No one conduit segment shall be more than 30 m (100 ft) in length with no more than two 90 degree bends allowed in one segment. Exceeding these limits increases the coefficient of friction in the cable pulling operation and can damage the cable by possibly stretching or changing the cable geometry.

3.2.4.3 Elbows and bends

Factory-manufactured bends (sweeps) are recommended for conduit installation, especially for conduits over 35 mm (1.25 in) trade size. Reducing the recommended bending radius can result in cable damage during the cable pulling process. Field manufactured bends, if not accurately fabricated, may turn out elliptical (oval) in shape rather than round. This elliptical shape is generally caused by the action of the tools used to bend the conduit. See Table 1 (next page) for minimum bend radii of conduits.

If needed, flexible metal conduit may be used. However, the length of flexible metal conduit should be less than 6 m (20 ft) a run. Flexible metal conduit runs exceeding 1.8 m (6 ft) shall be bonded by an equipment bonding conductor.

3.2.4.4 Conduit terminations

Conduits that enter a room (e.g., telecommunications room) should be terminated on the wall to enable orderly routing of the cables to termination

Table 1. Minimum conduit bend radius	
If the conduit has an internal diameter of...	The bend radius shall be at least...
50 mm (2 in) or less diameter	6 times the internal conduit diameter
More than 50 mm (2 in) diameter	10 times the internal conduit diameter

hardware within the room. Conduit ends should be positioned adjacent to a corner of the backboard (in the case of a single piece of plywood) or in the corner of the room (where multiple sheets of plywood are installed around the perimeter walls of the room). If conduits cannot be located in these positions, cable trays should be used to route the cables from one location in the room to another.

When entering from below grade or between floors, the conduits shall extend 25 mm to 75 mm (1 in to 3 in) above the floor slab or building structure, which will prevent cleaning solvents or other fluids from flowing into the conduit. Conduits shall be reamed and installed with bushings, which will mitigate sheath damage when pulling cable(s).

Where several large backbone cables are passing vertically through the room, a vertical cable tray or other suitable vertical attachment should be appropriately positioned to support the cables. When cable tray is used, the cables should be secured to the cable tray in an orderly fashion to ensure that they are properly supported and the entire weight of the cable is equally distributed over several cable tray rung supports.

3.2.4.5 Bonding and grounding conduits

Conduits shall be bonded to the equipment grounding system. Conduits shall be bonded to either the telecommunications main grounding busbar (TMGB) or to a telecommunications grounding busbar (TGB) where present.

Grounding bushings are typically installed on the end of the conduit. For electrical metallic tubing (EMT), a set-screw fitting is placed on the end of the conduit and the grounding bushing screwed on to the fitting and tightened using the appropriate tool. On intermediate metal conduit (IMC) and rigid metal conduit (RMC), a grounding bushing may be screwed onto the threaded end of the conduit and tightened until secure. A threadless grounding bushing, installed with set screws, is also available which can provide an alternate means for locating the ground lug.

In a TR or ER, each conduit can be attached to the channel stock with a conduit strap. A single conduit in each run of channel stock can be equipped with a grounding bushing. The entire section of channel stock can effectively be grounded using a single bushing and ground wire. An alternative method is to install a grounding connection onto the channel stock and then route the ground conductor to the nearest TMGB or TGB.

Where a small number of conduits are installed, a grounding bushing should be installed at the end of each conduit for the attachment of a ground wire, which connects to the TMGB or TGB. Conduits in close proximity to each other can be bonded together and one of them shall be bonded to the TMGB or TGB.

3.2.4.6 Securing conduit

Conduits shall be secured to prevent movement.

Throughout the conduit route, cross bracing may be used to stabilize the conduit(s), which will mitigate lateral movement during cable pulling operations. Stabilizing the conduits can be accomplished by the use of conduit straps, channel stock, or ATR placed at opposing angles (180 degrees opposite from each other). The same anchoring mechanisms can be used to secure the straps and cross braces as used to hang the conduits from the building structure.

When terminating conduits at a plywood backboard (e.g., in a telecommunications room), they should be secured to the top of the plywood backboard or just

above the backboard when entering from overhead. Securing and terminating conduits above the plywood backboard allows for full usage of the plywood backboard for termination and routing of cabling. Channel stock may be used to attach the conduits to the room wall.

3.2.4.7 Stub-up/stub-out conduits

These terms imply that a section of conduit is used to provide a pathway in a vertical and then horizontal direction from a point of termination. While similar in many ways, they are significantly different from an installation perspective. Stub-up/stub-out conduits are generally not grounded.

3.2.4.8 Stub-up installation

Stub-ups are usually single sections of small diameter metal conduit. They typically originate at a 103 mm (4 in) square box installed in drywall or paneling. The stub-up continues vertically through the wall cavity where it penetrates the wall cap and stubs up into the ceiling area. It terminates at that point and is equipped with a conduit bushing and a pull string. Sometimes the stub-up is equipped with a 90-degree bend that is turned back into the room, especially when installed in fire- or smoke-rated walls.

3.2.4.9 Stub-out installation

Stub-outs are short runs of small diameter metal conduit. They typically originate at a 4 inch square box installed in drywall or paneling. The stub-out continues vertically through the wall cavity, where it penetrates the wall cap, and continues into the ceiling area. In a typical installation, the conduit continues through the ceiling area and into an adjacent hallway. The conduit may terminate as it exits the wall into the hallway, or it may continue to another type of supporting structure such as a cable tray or ladder rack. It terminates at that point and is equipped with a conduit bushing and a pull string.

3.2.5 Supports

There are many types of supports available for conduit installation. Three examples of conduit supports

are pipe hangers, trapeze, and a one piece conduit hanger.

A pipe hanger is a pear shaped device that is attached to an ATR. It is suspended from the building structure by an anchor or beam clamp and a section of ATR. Anchors are installed in the concrete structure of the above floor. When concrete is not available and steel trusses are installed in the building, beam clamps can be used to support the ATR and hanger. The selection of anchors and beam clamps should be determined by the load of the conduit and cable to be supported. The ATR is attached to the pipe hanger with nuts and lock washers. The assembly is then capable of supporting the conduit that is installed through the pipe hanger.

Another type of conduit support is a trapeze. This is a device that is made by using two ATRs and a section of channel stock. The ATR is suspended from the building structure and attached to each end of the channel stock using appropriate nuts and washers. The conduits are then attached to the channel stock with conduit straps and locked in place.

A third type of conduit support is a one piece conduit hanger. This is a device that is manufactured in such a way that the compression bolt is part of the hanger itself and, when loosened, it will not come off the hanger. This type of hanger can be mounted directly to the building structure, to red iron, or to a specialized hanger mount.

3.2.6 Surface raceway

Surface raceway is available in both metallic and nonmetallic versions. When installing surface raceway, follow manufacturer's instructions. Metallic surface raceway shall be bonded to the equipment grounding system.

3.3 Spaces

3.3.1 Plywood

Plywood backboards are recommended to be installed around the entire perimeter of rooms (e.g., telecommunications room). This will allow cables to

be installed and terminated around the walls of the room, now or in the future. It may also facilitate attaching cables that pass through vertically to rooms above or below.

A minimum of two walls should be covered with rigidly fixed 19 mm (0.75 in) A-C grade plywood, preferably void free, 2.4 m (8 ft) high, capable of supporting attached equipment. The plywood should be installed with the “A” grade side exposed and the “C” grade side against the building wall or structure. Plywood should be either fire-rated or covered with two coats of fire retardant paint as required by the Authority Having Jurisdiction (AHJ).

Plywood sheets used for backboards should be installed with the longest dimension reaching from the floor level up toward the ceiling to its 2.4 m (8 ft) height. Plywood shall be installed in such a manner that there is no separation between adjacent sheets. When installing plywood in a corner, the plywood backboard shall be installed to form a smooth, tight, gap-free corner.

The plywood backboard shall be secured on top of existing drywall or to wall studs of the room. When installing plywood on drywall, which has already

been installed on metal studs, verify the load rating of the wall before installing the plywood. If the load rating will permit this type of installation, use a minimum of 6 mm (0.25 in) toggle bolts (butterfly bolts) to ensure the stability of the installation. Toggle bolts should be installed at approximately 610 mm (24 in) spacing around the entire perimeter of the plywood sheet. The toggle bolts should be installed 50 mm (2 in) from the edges of the sheet of plywood on 610 mm (24 in) centers. Figure 8 illustrates plywood installation over drywall that is attached to metal wall studs.

3.3.2 Equipment racks

Equipment racks should meet the requirements of ANSI/EIA-310-D. Equipment racks shall be secured to the building structure and should be accessible from the front and rear. Typical spacing is 914 mm (36 in) in front and back of the rack, and 762 mm (30 in) on the sides. Where equipment racks are separated from a wall, cable trays should be installed from the wall to the top of the equipment racks. This provides a pathway for cables to be routed between equipment racks. Transitions between cable trays and equipment racks shall be equipped with a means that ensures minimum cable bend radii is maintained. All

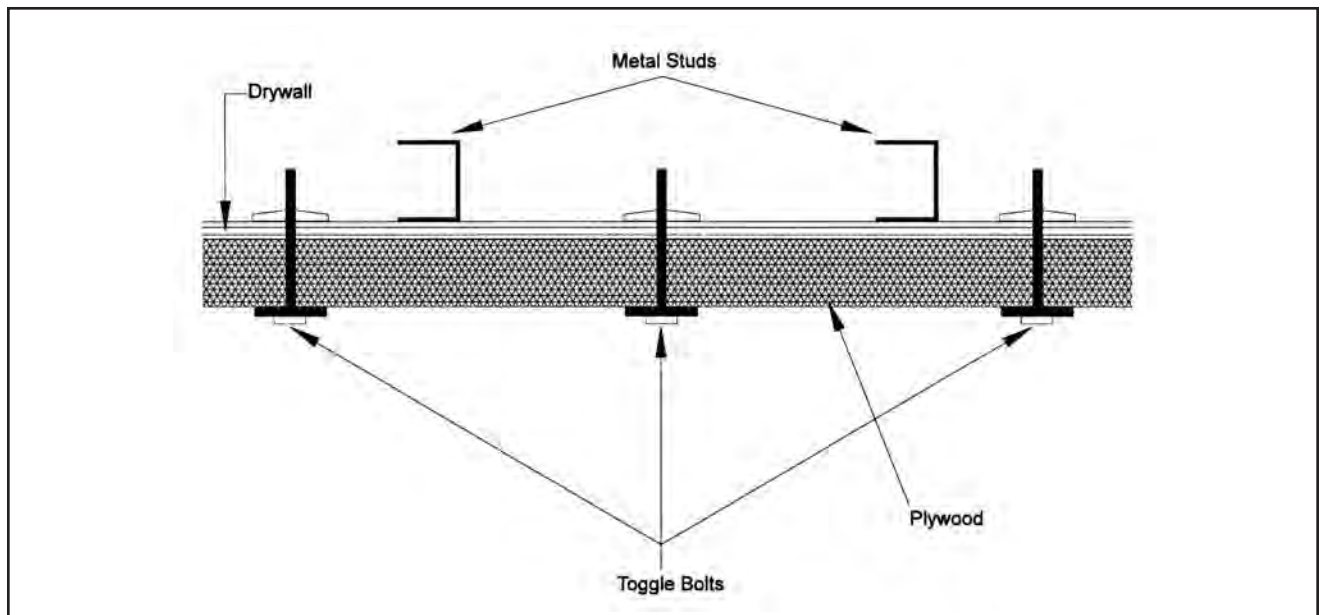

Figure 8—Plywood installation over drywall using toggle bolts

racks shall be bonded to the TGB or TMGB using a minimum 6 AWG copper conductor.

Cables should be routed on the rear sides of the rack using cable management accessories attached to the rear of the rack's vertical channels or in cable management channels on the sides of the rack.

3.3.3 Floor mounted cabinets

Ensure that the floor-mounted cabinets will fit the footprint allocated for them prior to installation. If there is a question regarding the space allocated refer to design drawings or contact the designer for further clarification.

Cable access to floor mounted cabinets is normally provided by knockouts (pre-punched holes) in the cabinet side, top, or bottom. Cable trays and ladder racks provide a means of routing cables to the cabinet. Transitions between cable trays and cabinets shall be equipped with a means that ensures minimum cable bend radii are maintained. Verify the cable installation methods specified by the manufacturer prior to attempting to install cabinets.

When floor mounted cabinets are used, the grounding and bonding instructions shall be followed.

3.3.4 Wall-mounted equipment racks and cabinets

When wall-mounted equipment racks and cabinets are required, the grounding and bonding instructions shall be followed.

3.4 Bonding Infrastructure

3.4.1 General

Grounding and bonding are terms that are used to define the practice of connecting all metallic components of a system together to a main building ground electrode, for the purposes of reducing or eliminating the differences of potential between all of the utilities inside of the building structure. See ANSI /J-STD 607 A.

3.4.2 Bonding conductor

Ground conductors and a ground bus shall be installed so that they are not obstructed by cable trays, cables, or terminating hardware. Ground wires and bonding conductors should always be installed in the straightest and shortest route between the origination and termination point. A minimum bend radius shall not be less than eight times the conductor diameter. A sharp bend may interfere with the effectiveness of the grounding system since it will modify the characteristics of the grounding path.

3.5 Installing cable support systems

3.5.1 General

Cable support systems typically installed for telecommunications include the following:

- Cable trays and associated hardware
- Ladder racks and associated hardware
- Enclosed cable pathways and associated hardware
- Plywood backboards, straps, distribution-rings, hangers, fasteners, and J-hooks
- Conduits and associated hardware

Support systems provide a pathway for the cable, thus minimizing stress that could cause damage to the copper pairs or glass strands inside a cable sheath. The following installation steps are general in nature and additional steps may be required, depending on the size, quantity, and load rating of the individual supporting structures. Telecommunications designers should provide all the information in their design documents that will allow the installer to select the necessary hardware and employ proper methods to install these structures.

Since these support systems are used to support both backbone cables and horizontal cables, they are found in most areas of the buildings. It may be the case that other utilities (i.e., HVAC, plumbing, electrical) or structural obstructions will require that the cable support system change elevation and direction. Careful planning is important to minimize changes

in direction which can be costly from a material as well as labor perspective.

3.5.1.1 Steps—install cable support systems

1) Obtain blueprint/specifications/designer's documents.

- Determine the size, type, and quantity of pathways to be installed.
- Determine the proposed route of the pathways between rooms and from rooms to work areas.
- Identify any obstructions along the proposed route and determine how to overcome them.
- If it is necessary to pass through any walls, be prepared to make the required penetration—concrete, concrete block, drywall, or other wall construction.
- When installing cables in a suspended ceiling without permanent pathways, avoid cable paths that introduce obstacles.
- Identify the plan to support cable in suspended ceilings and what type of hardware will be installed.

2) Verify load capacity of the cable support system.

Verify by:

- Reviewing the telecommunications designer's documents.
- Determining the weight of individual types and sizes of cable to be installed.
- Identifying the building structure to ensure the attachment of the support system is designed for that structure.

3) Verify the load capacity of existing cable support structures.

Where existing supports are to be used, visually examine them to determine if they are firmly attached, not worn or broken, and are capable of bearing the extra weight.

4) Verify cable support installation accessibility.

Examine the following:

- Area where the building beams and other structural elements are located.
- Area where the concrete floor slab above is accessible and usable for installing anchors or other cable supports directly to them.
- Paths in all directions from the point of observation to confirm if the pathway is clear for cable supports.

5) Metallic cable separation.

- Maintain specified distances from possible sources of EMI exceeding 5 kVA (*see Table 2, next page*).
- For safety purposes, keep power cables physically separated from telecommunications cables.
- For branch circuits of 5 kVA or less no additional separation should be necessary. For unusual situations when excessive noise is present on branch circuits, see TIA 569-B Annex C, "Noise reduction guidelines."

NOTE—Optical fiber is immune to the effects of EMI.

6) Verify material and tool availability.

Before beginning the installation of a cable support system, be sure that the required materials, hand tools, and power tools are available. This should also include safety tools such as safety glasses and, where required, hardhats.

7) Mount distribution-rings.

- Review the designer's drawing and specifications to determine exact placement, quantity, size, and type of distribution-rings.
- Install the distribution-rings, working from the top left side of the plywood backboard to the bottom right side of the plywood backboard:

Table 2. Minimum separation distances from possible sources of EMI exceeding 5 kVA	
Condition	Minimum Separation Distance
Unshielded power lines or electrical equipment in proximity to open or nonmetal pathways.	610 mm (24 in)
Unshielded power lines or electrical equipment in proximity to a grounded metal conduit pathway.	300 mm (12 in)
Power lines enclosed in a grounded metal conduit (or equivalent shielding) in proximity to a grounded metal conduit pathway.	150 mm (6 in)
Electrical motors and transformers.	1200 mm (47 in)

- Measure the location of the first distribution-ring to be installed according to the designer’s documents.
 - Position the distribution-ring on the back-board and install the screws to secure the distribution-ring.
- 8) Installing J-hooks.
- Determine the J-hook size required in each cable path and lay them out along the cable route, a maximum of 1.5 m (5 ft) apart.
 - Identify the location of the first J hook to be installed.
 - Position the J-hook at its designated location and mark the holes for the anchors.
 - Pre-drill the holes and install the anchors. depending on the type of structure, (i.e., a masonry structure will require one type of anchor while metal structures or drywall will require others).
 - Install the anchors.
 - Reposition the J-hook at the anchor(s).
 - Install the screw(s) through the hole(s) in the J-hook and into the anchor, securing the J-hook to the anchor(s).

- Install the remaining J-hooks using the same procedures.

9) Install cable tray systems.

The process of installing cable tray is manufacturer specific, due to the many different sizes, types, and configurations. Consult the manufacturer’s specifications and installation guidelines prior to installing these pathways.

Trays can be installed parallel to and against a wall or can be suspended from the building structure using ATR. They can also be supported using channel stock or manufacturer specific supports.

10) Install conduits.

See subclause 3.2.4.2, subclause 3.2.4.3 and TIA 569-B for maximum length of conduit and bends between pull points and pull box sizing.

All metal conduits installed for the placement of telecommunications cable shall be bonded to the equipment grounding system.

All conduits shall have a pull string installed.

11) Conduit hangers.

Conduits are suspended from the building structure using a variety of hangers. These hangers are available in many sizes and types depending on the type of conduit and method used to install the hangers. Refer to the manufacturer's specifications for use of the type and size for the conduit hanger to be installed.

12) Installing wireway.

Wireways are different from cable trays in that they are completely enclosed pathways. They usually feature a hinged cover or one which snaps in place. They are available in a number of sizes and shapes, depending on the manufacturer. As with cable trays, the installation methodology is directly related to the manufacturer's guidelines. All metallic wireways installed for the placement of telecommunications cable shall be bonded to the equipment grounding system.

13) Pathway documentation.

The pathway shall be identified on the construction drawings and physically marked with a label that identifies it and states its origin and terminus. (See ANSI/TIA 606-A.)

14) General housekeeping.

It is important to clean up after a work operation when installing pathways. In general, equipment of sufficient size is required to install pathways and the materials are bulkier – thereby taking up space in the hallways and passageways of the building. This causes congestion and, if left in place, can impact the work efforts of others.

Hangers, their associated hardware, anchors, screws, and other materials can present a safety hazard to workers and should be stored during work operations and upon completion of the day's activities. If a work area cannot be cleaned, safety cones and barricades should be placed to prevent accidental intrusion into the work area by others until the work is complete and the area is cleaned.

4. Pulling Cable

4.1 General

Backbone cable is typically a high pair count copper cable (25- to 2400-pair), or high strand count optical fiber cable. Horizontal cable is typically 4-pair balanced twisted-pair with a performance level of category 3, 5e, or 6, or 2- to 6-strand optical fiber. For indoor optical fiber cable, the preferred color-coding scheme and written nomenclature for premises cable jackets are specified in ANSI/TIA 598-C (see Table 3). An example of the nomenclature used is that of a 12-fiber cable containing eight 50/125 μm and four 62.5/125 μm fibers. The nomenclature for such a cable may include “12 Fiber — 8 x 50/125, 4 x 62.5/125” in the jacket print statement. For ultraviolet (UV) stabilized indoor/outdoor cable, the preferred color is black.

When cable is received at the job site, the cable length should be verified to ensure the cable will reach between the end points. Inspect both ends of the cable to verify the footage markings on the outer jacket and compute the actual length of the jacket. The cable shall be identified, labeled, and the as built updated to reflect the work operation. As built plans shall be provided to the owner as a permanent record.

See BICSI Information Transport Systems Installation Manual.

4.2 Cable pulling setup

4.2.1 Overview

A good cable pulling setup means all materials are in place so the cables can be handled properly and safely. A cabling contractor may need specialized equipment capable of holding large reels. Smaller equipment, such as cable trees, may be used to handle the many reels of cable containing low pair count cable.

The pathway of a cable must be free of sharp bends and turns. The manufacturer’s recommended pulling tension and minimum bend radius (while under tension) shall not be exceeded. The use of cable lubricants can significantly reduce friction and speed cable installation (e.g., within a conduit). A lubricant should be selected based on cable manufacturer’s recommendations.

When large, high pair count copper cables are installed in conduits, the pulling of the cable places significant tension on the conduit. A winch is gener-

Table 3. Preferred color coding scheme for premises cable jackets (ANSI/TIA 598-C)

Fiber Type	Jacket color		
	Non-military Applications	Military Applications	Suggested Print nomenclature
Multimode (50/125)	Orange	Orange	50/125
Multimode (50/125) (850 nm laser-optimized)	Aqua	—	850 LO 50/125
Multimode (62.5/125)	Orange	Slate	62.5/125
Multimode (100/140)	Orange	Green	100/140
Single-mode (NZDS)	Yellow	Yellow	SM/NZDS SM
Polarization Maintaining Single-mode	Blue	—	Undefined

ally employed in this high pair count placing operation. Sometimes the winch is anchored to the building or attached directly to the conduit. This tension causes swinging and swaying of the conduit and its hangers. Excessive movement of the conduit can cause the hangers to loosen and possibly come free. If this happens, the conduit and its cable could fall to the floor resulting in damage to the cable, the building, and individuals.

Communication with co-workers is essential in every cable pull. Each of the co-workers should be prepared to alert the person pulling the cable, to ensure the cable is traversing the route smoothly without twisting, kinking, or getting bound up.

4.2.2 Pulling horizontal cable in conduit

4.2.2.1 Overview

Horizontal cable is installed between the telecommunications room and work area outlets. Cable shall not be bent or kinked. Should the cable be damaged during installation, do not attempt to repair, instead replace the entire cable.

It is recommended to label cables and their reels prior to pulling cable into place. It is easier to identify and label the cables before they are pulled through the conduit.

4.2.3 Pulling horizontal cable in open ceiling

The procedure for cable installation in open ceilings is different from that in conduits. Cables shall be supported according to local code requirements and manufacturer provided instructions.

4.2.4 Pulling backbone in vertical pathway— from top down

Cable is generally easier to install from the top down rather than from the bottom up because gravity helps with the pull. When pulling cable from top down, a reel brake may be needed. A reel brake is a mechanical device used to stop or slow a freewheeling reel, thus keeping it from unreeling too fast due to gravity. Pulleys may be needed to handle the cable from the reel location to the point where it will be lowered to

lower floors. In the room where the cable will enter the vertical pathway, a bullwheel may be required to ensure that the jacket is not damaged as it enters the pathway.

4.2.5 Pulling backbone in vertical pathway— from bottom up

When pulling cable from bottom up, a winch may be needed. Cable sheaves may be necessary to handle the cable from the reel location to the point where it will be pulled up to upper floors. In the room where the cable will enter the vertical pathway, a bullwheel may be required to ensure that the jacket is not damaged as it enters the pathway. Installers should be located on each floor through which the cable will pass as well as the top floor where it will terminate. These individuals shall be equipped with tools to perform critical tasks during the placing operation.

4.2.6 Pulling backbone—horizontal

Backbone cable is used to interconnect telecommunications rooms on the same floor.

Cable sheaves may be necessary to handle the cable from the reel location to the point where it will be pulled. In the room where the cable will enter the horizontal pathway, a bullwheel may be required to ensure that the jacket is not damaged as it enters the pathway.

4.2.7 Cable pulling precautions

To verify receipt of undamaged cable, while the cable is still on the reel, the installer should verify that there is continuity with the cable still on the reel. For copper cable, continuity can be verified by use of an ohm-meter.

For optical fiber cable, continuity can be verified by shining a light source (e.g., flashlight) into the fiber strands or using a power meter or optical time domain reflectometer (OTDR).

Innerduct may be placed inside conduit, through sleeves, or placed in cable trays to facilitate cable pulls, cable removal, and to relax pulling tension exerted on the cable.

5. Firestopping

5.1 General

Reestablishing the integrity of fire rated walls, floors, and ceilings is an essential part of a cabling installation.

Penetrations through fire-rated assemblies made during the installation and any holes created by the removal of existing penetrants shall be sealed to the original rating of the fire rated architectural structures and assemblies using manufacturer approved methods in accordance with local code requirements. See ANSI/TIA 569-B, Annex A for information regarding firestops.

The term firestop refers to the installation of “qualified/listed” firestop materials in holes made through fire-rated floors, walls, or ceilings for the penetration of pipes, cables, or other construction/building, service/utility items. Firestop products are used to restore the opening to the original fire-rated integrity. Most common requirements are for 1, 2, or 3 hours. In rare instances, a 4-6 hour rating shall be provided.

There are two basic types of penetrations:

- Through penetration is a hole made in a fire-rated wall or floor to run pipes, cables, or any type of building service, completely through from one side of the fire barrier to the other side.
- Membrane penetration is a hole in one side of a fire-rated wall or floor for a single surface-barrier penetration. (i.e., an electrical outlet/switch box).

Therefore, the installer:

- Cannot substitute products that are not part of the qualified assembly.
- Cannot add more of a product to get a higher rating.

- Can be held personally responsible for improperly firestopping or not firestopping.
- Can contact the manufacturers to get written assistance for situations not covered in their installation practices for qualified assemblies.
- Must follow manufacturer requirements for conduit fill ratios.

There are ten basic types of firestop products:

- Mechanical systems
- Mortar/compounds
- Composite sheets
- Collar/devices
- Blankets
- Caulks/sealants
- Putty
- Wrap strips
- Pillows/bags
- Sprays

Mechanical systems consist of manufactured elastomeric components pre-sized and shaped to fit around standard cables, tubes, and conduits. These products are made of several substances which resemble rubber and are flexible. These systems use mechanical pressure to hold the elastomeric components in place and to provide a tight seal around the penetrating devices. Whether or not frames are included, some means of applying compression to the modules is required.

Non-mechanical firestop systems are generally pliable. These include products such as putties, caulks, blan-

kets, silicone foam, pillows, and other types of materials that can be molded to fit into an opening to seal it.

When firestopping conduits care must be taken to not exceed conduit fill ratios provided by the manufacturer. Failure to comply with these requirements will prevent the application of the proper amount of firestop being installed around the penetrating cables and not allow the intumescent properties of the firestop material to be realized. This will lead to failure of the firestop.

5.2 Typical installations

5.2.1 Sealing a floor penetration with putty

The following illustrations show an example of installing a putty seal from one side of a floor penetration.

- 1) Tear off a small portion of the putty.

NOTE: Use a drop cloth or other cover to protect the floor surface from the putty and insulation material. See Figure 9.

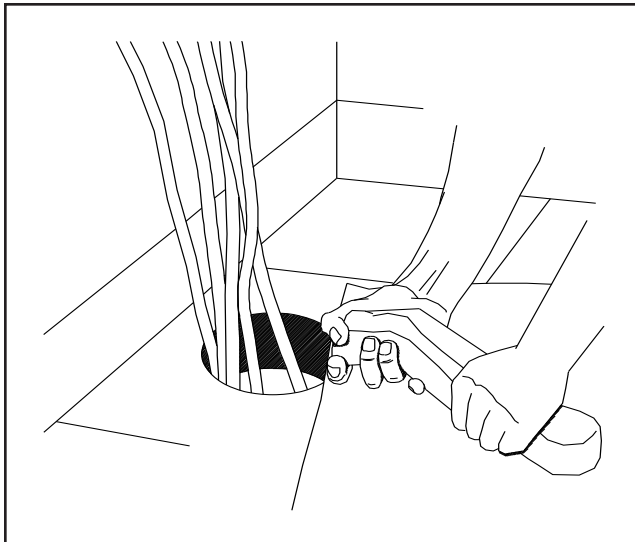

Figure 9—Tear off putty

- 2) Use the putty to build a bottom in the penetration, according to the manufacturer's instructions. See Figure 10.

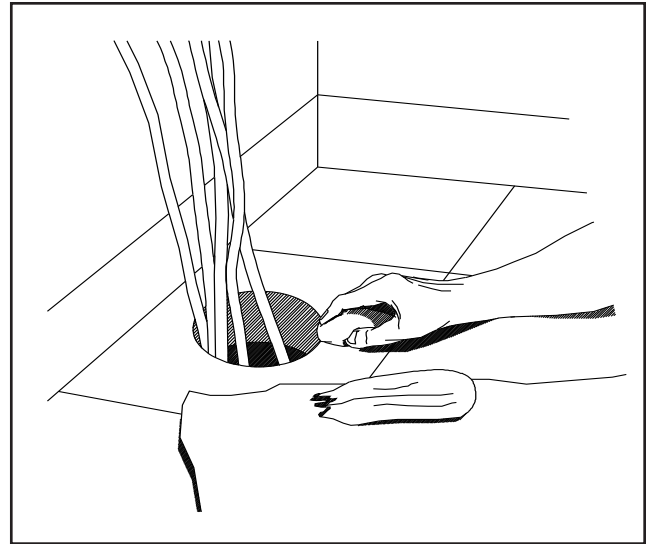

Figure 10—Building bottom of penetration seal

- 3) Fill the penetration with ceramic fiber or rock wool fill, stopping far enough from the upper rim to allow for a top layer of putty at the manufacturer's recommended thickness. See Figure 11.

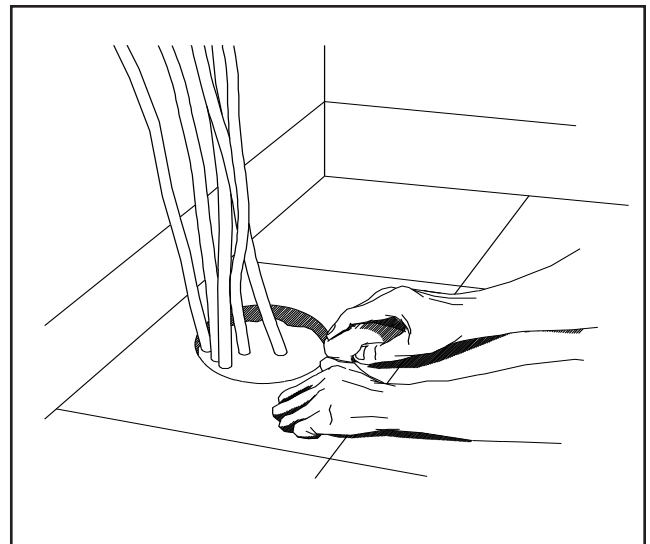

Figure 11—Filling the penetration

4) Use the putty to build a top on the penetration, according to the manufacturer's instructions. See Figure 12.

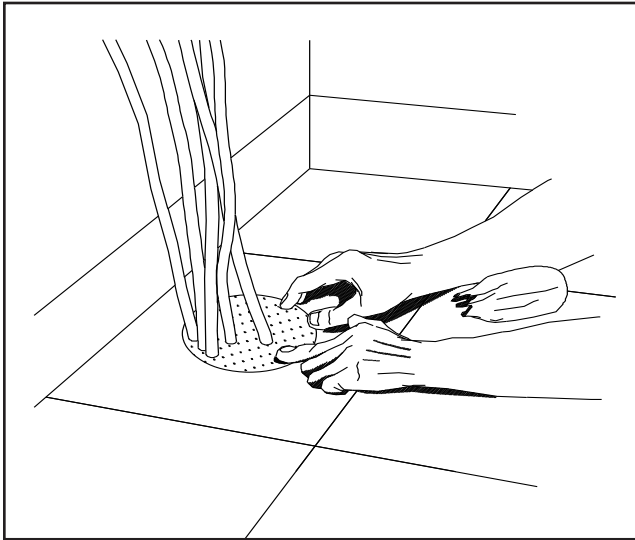

Figure 12—Building top on penetration

5.2.2 Sealing an outlet box with putty

To seal an outlet box, follow the steps below.

1) Press a pad of putty into place, covering one side of the outlet box. Ensure that the pad overlaps at the top, bottom, and sides, as shown in Figure 13.

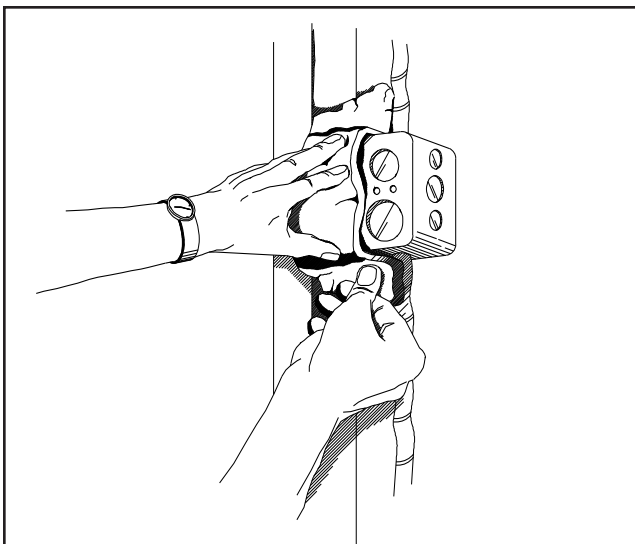

Figure 13—Overlap the pad on outlet box

2) Press a second pad of putty, if needed, into place on the other side of the box, as shown in Figure 14.

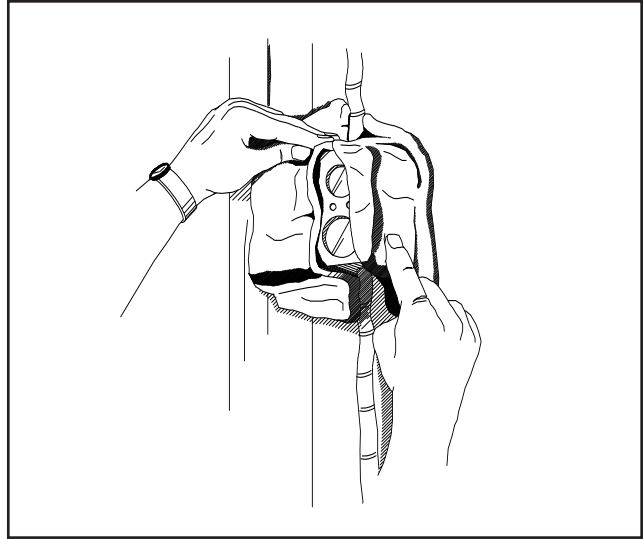

Figure 14—Second pad of putty on outlet box

3) Press the seams together to join the two pads, as shown in Figure 15.

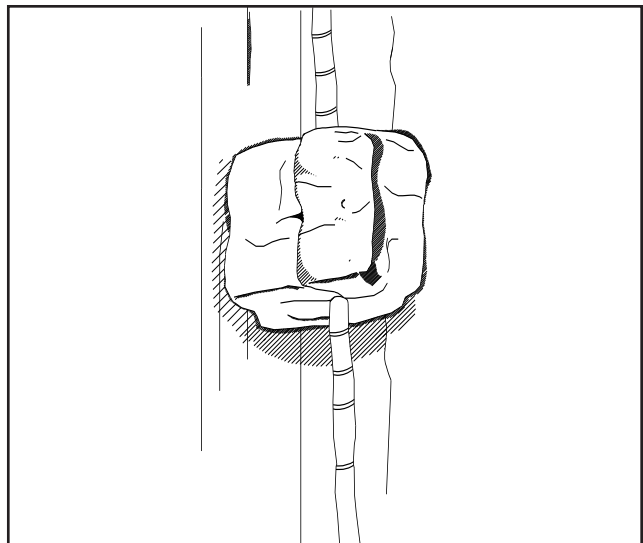

Figure 15—Joining the pads on an outlet box

5.2.3 Steps—restore penetrations (general)

1) Firestop conduits, pipes, and innerducts in brick, concrete block, or concrete wall. See Figure 16.

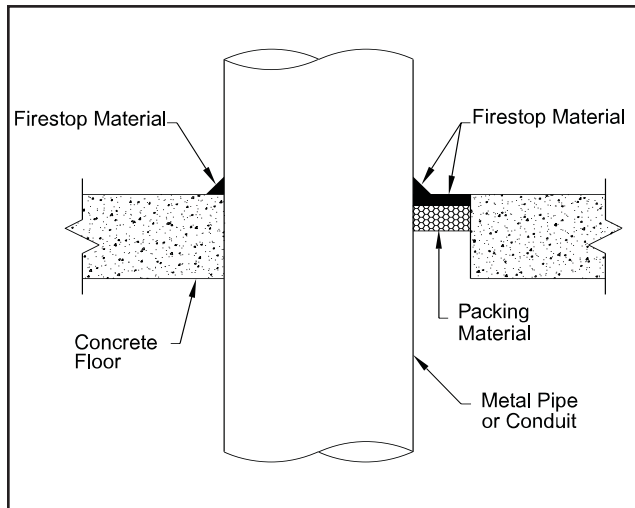

Figure 16—Conduit penetration through masonry wall or floor

The requirements for firestopping are variable and are directly dependent upon:

- Fire-barrier construction
- Material passing through the firewall
- Hourly rating required
- Opening size
- Installing the materials according to manufacturer-tested methods

2) Firestop floor penetrations.

Sealing of cored or sleeved openings in floor slabs containing pipes, cables, or innerducts requires knowledge of floor thickness, floor construction, hourly fire rating required, opening size, annular space, sleeves, and materials selection.

3) Firestopping drywall. See Figure 17.

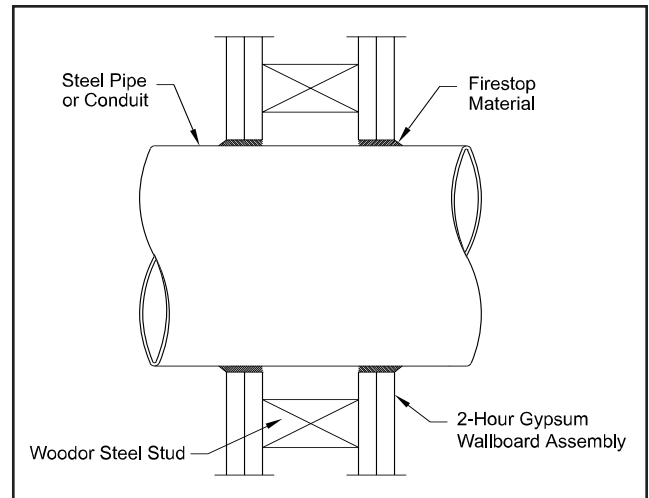

Figure 17—Fire seal of drywall

- Requirements for firestopping are variable and are directly dependent upon hourly rating, opening size, annular space, sleeves, along with type and number of penetrants.
 - Drywall penetrations are typically required to have firestopping installed symmetrically on both sides of the wall to restore fire rating.
- 4) Firestopping all applicable penetrations.
- Inspect all cable runs for any openings made through fire-rated walls as part of structured cabling system.
 - If sleeves have been used, be sure to firestop the wall penetrations on both sides and each end of the sleeve itself.
- 5) Firestop cable tray.

Penetration by a cable tray in a firewall is only permitted by the AHJ. Generally the tray is placed against each side of the firewall and a number of appropriately sized sleeves are installed for cables to pass through.

If a cable tray penetrates directly through firewalls, specific manufactured seal systems should be obtained. Figure 18 illustrates an example of the components of a qualified seal system.

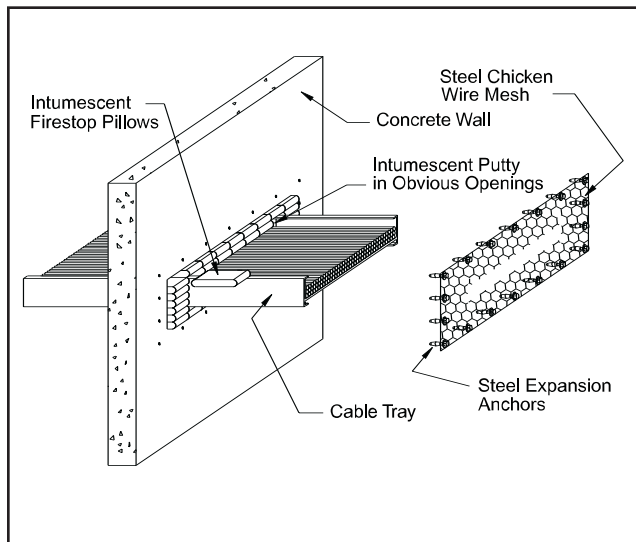

Figure 18—Fire seal cable tray penetration

6. Cable Terminations

6.1 General

Cable termination involves the organizing of cables by destination, forming and dressing cables, and labeling, as well as actually creating a connection with a copper or fiber conductor.

NOTE –Wear safety glasses during all work operations.

6.2 Pre-termination functions

Cable termination preparation not only improves the quality of the job but also decreases the amount of time required for termination.

The performance of pre-termination functions involves organizing the cable by destination. Cable to be terminated should be placed at the point of termination and must also be identified to ensure it is terminated in the designated position. Cable connection is not complete until all terminations are identified and labeled.

Alien crosstalk is associated with copper balanced twisted-pair cabling and an issue of which the installer must be aware. This issue can be mitigated by allowing cables to have a more natural lay rather than forming tight bundles and allowing cables to be run next-and-parallel to each other. While forming and dressing the cable at the point of termination may be visually pleasing, doing so for longer distances, such as within a cable tray, may lead to alien crosstalk performance issues. Separation of balanced UTP cables should follow the guidance of ANSI/TIA 568-B.1-10 and TIA/TSB 155.

6.3 Copper IDC termination

6.3.1 General

Copper terminations are used for balanced twisted-pair cabling and the use of insulation displacement

contact (IDC) is recommended. When terminating balanced twisted-pair copper cable:

- Remove only as much cable jacket as is required for termination and trimming.
- Follow the manufacturer’s instructions for mounting, termination, and cable management.
- Minimize the amount of untwisting in a pair as a result of termination to connecting hardware. For untwisting cabling, maintain pair twists as close as possible to the termination point. The amount of untwisting shall not exceed:
 - 25 mm (1 in) for category 3 cables.
 - 13 mm (0.5 in) for category 5e and higher cables.

NOTE—This requirement is intended to minimize untwisting of cable pairs and the separation of conductors within a pair. It is not intended as a twist specification for cable of jumper construction.

The T568A and the optional T568B wiring schemes (see Figure 19) are recognized for use with horizontal copper cable. Only one of the wiring schemes shall be used in a project.

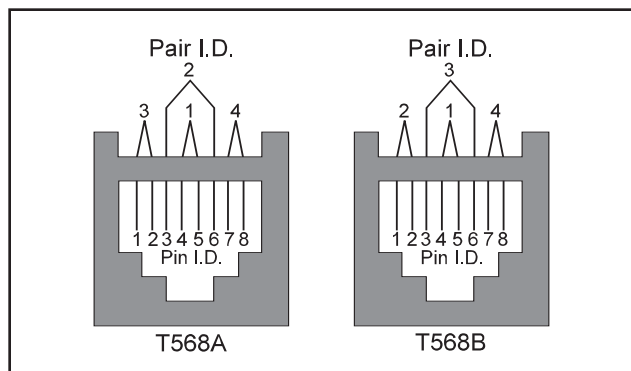

Figure 19—Wiring schemes

ScTP manufacturers provide detailed instructions on how to terminate the shield. This procedure is manufacturer dependent, and the specific method provided for the selected product shall be followed for shield effectiveness over the capable bandwidth.

6.3.2 Steps—IDC termination

1) Using a sheath removal tool, remove the cable sheath in accordance with the termination equipment manufacturer’s specifications.

2) Binder groups are found in 50 pair cables and above. Separate and identify binder groups. See Table 4.

3) Limit the untwisting of cable pairs to the minimum length required to make the termination. The untwist of cable pairs shall not exceed 13 mm (0.5 in).

4) Terminate cable according to connecting hardware manufacturer’s recommendations.

Table 4. Color-code chart up to 600 pair

Pair Number	Tip	Ring	Binder group	Pair Count
1	white	blue	white-blue	001-025
2	white	orange	white-orange	026-050
3	white	green	white-green	051-075
4	white	brown	white-brown	076-100
5	white	slate	white-slate	101-125
6	red	blue	red-blue	126-150
7	red	orange	red-orange	151-175
8	red	green	red-green	176-200
9	red	brown	red-brown	201-225
10	red	slate	red-slate	226-250
11	black	blue	black-blue	251-275
12	black	orange	black-orange	276-300
13	black	green	black-green	301-325
14	black	brown	black-brown	326-350
15	black	slate	black-slate	351-375
16	yellow	blue	yellow-blue	376-400
17	yellow	orange	yellow-orange	401-425
18	yellow	green	yellow-green	426-450
19	yellow	brown	yellow-brown	451-475
20	yellow	slate	yellow-slate	476-500
21	violet	blue	violet-blue	501-525
22	violet	orange	violet-orange	526-550
23	violet	green	violet-green	551-575
24	violet	brown	violet-brown	576-600
25	violet	slate		

6.4 Fiber termination

In telecommunications, there are two specific types of optical fiber used: multimode and single-mode. Each specific type of fiber has its own characteristics. Multimode optical fiber has an outside diameter of 125 μm. The glass core of the fiber, which carries the optical signal, has a diameter of 50 μm or 62.5 μm. Single-mode optical fiber has an outside diameter of 125 μm. The glass core of the fiber, which carries the optical signal, has a diameter of 8-9 μm. The optical fibers within cables are color coded as shown in Table 5.

Optical fiber cores must be precisely aligned between connecting cables to ensure that the maximum transfer of light energy is obtained. Termination procedures for optical connectors in the field vary by manufacturer. Listed below are some of the various methods:

- Heat-cured termination: A fiber connector termination method requiring field polishing using an adhesive that requires heat for curing.
- Crimp termination: A fiber connector termination method requiring field polishing using a mechanical means to secure the fiber.
- Anaerobic termination: A fiber connector termination method requiring field polishing using an adhesive and catalyst that cures very quickly.

- Pre-polished connectors: A fiber connector termination method using mechanical means to hold the fiber against a preinstalled and factory polished fiber sub in the ferrule of the connector.

Warning:

- 1) Care should be used when handling fibers so as not to break them, or to handle them in such a way that they could penetrate your skin. Safely dispose of fiber shards per your company’s practice.
- 2) Never look into the ends of an optical fiber as the transmitted light may be invisible and cause eye damage.

6.5 Copper cable splicing

Copper cable splicing is allowed only in backbone cable—never for horizontal cable which extends between the telecommunications room and the work area.

Two common modular (groups of pairs) splicing techniques are in-line and foldback. Foldback splicing is the preferred method, where practicable:

Fiber Number	Color	Fiber Number	Color	Fiber Number	Color
1	Blue	13	Blue/Black Tracer	25	Blue/Double Black Tracer
2	Orange	14	Orange/Black Tracer	26	Orange/Double Black Tracer
3	Green	15	Green/Black Tracer	27	Green/Double Black Tracer
4	Brown	16	Brown/Black Tracer	28	Brown/Double Black Tracer
5	Slate	17	Slate/Black Tracer	29	Slate/Double Black Tracer
6	White	18	White/Black Tracer	30	White/Double Black Tracer
7	Red	19	Red/Black Tracer	31	Red/Double Black Tracer
8	Black	20	Black/Yellow Tracer	32	Black/Double Yellow Tracer
9	Yellow	21	Yellow/Black Tracer	33	Yellow/Double Black Tracer
10	Violet	22	Violet/Black Tracer	34	Violet/Double Black Tracer
11	Rose	23	Rose/Black Tracer	35	Rose/Double Black Tracer
12	Aqua	24	Aqua/Black Tracer	36	Aqua/Double Black Tracer

With the in-line splicing method, wire is placed in a straight-across arrangement and provides for little wire slack (see Figure 21). The in-line method is not designed to be rearranged and should receive minimum handling. The foldback splicing method allows the conductors to be folded into the splice which in turn provides for maintenance, rearrangement, and transfer of the conductors. The foldback method (see Figure 22) typically requires more cable be stored within the splice and could increase the size of the needed splice closure.

The splice connecting hardware will be selected by the designer to meet the application requirements. Follow the equipment manufacturer’s installation guidelines.

The installer should pay particular attention to:

- Check cable shield for presence of unsafe voltages.
- Bond cable shields across the splice before splicing (see Figure 20).

- Bond cable shields to ground.

6.6 Optical fiber cable splicing

There are two major categories of field-splicing methods for optical fibers—fusion and mechanical. Both single-fiber and multiple-fiber (typically 6- or 12-fibers) splicing methods are available.

Only fibers with the same core and cladding dimensions and similar performance characteristics (bandwidth) shall be spliced (e.g., 50 μm core to 50 μm core; 2000 MHz•km to 2000 MHz•km).

The splice hardware will be selected by the designer to meet the application requirements. Follow the equipment manufacturer’s installation guidelines.

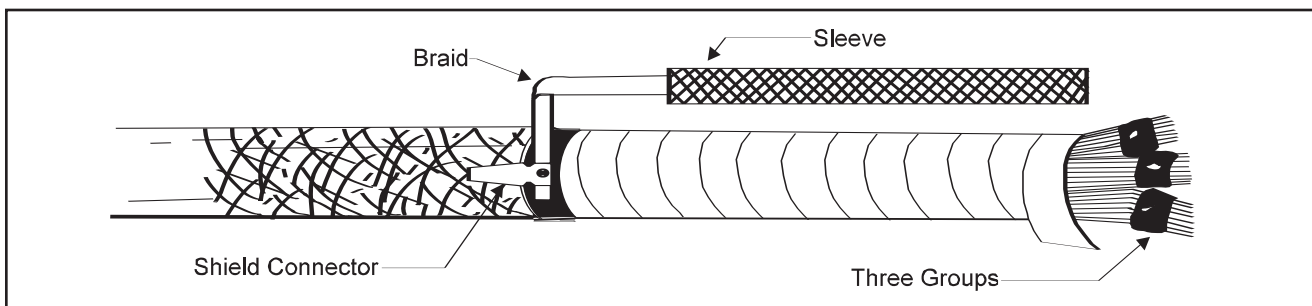

Figure 20—Shield bond connector and braid

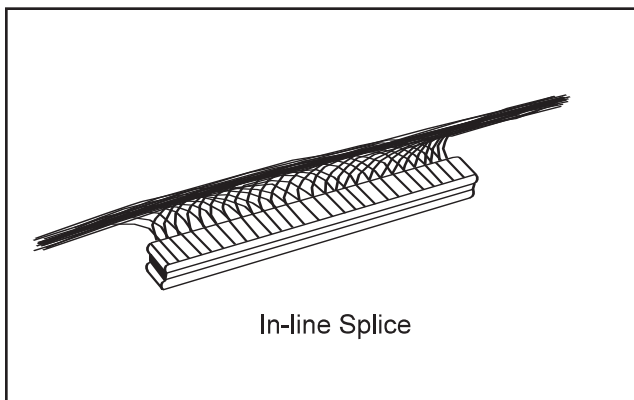

Figure 21—In-line splice configuration

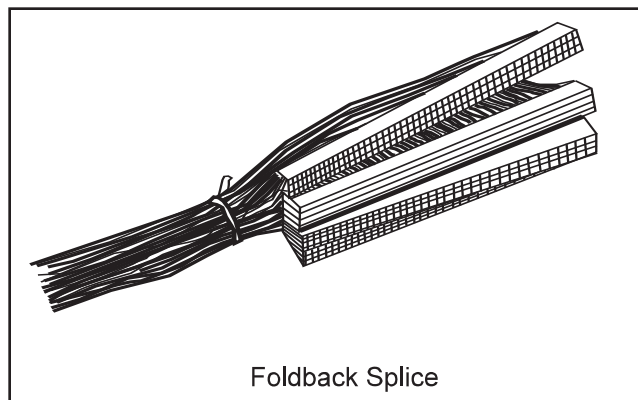

Figure 22—Foldback splice configuration

7. Installation Verification

Installation conformance is performed through a systematic method that ensures the installation has been completed in accordance with industry standards and the terms and conditions of the installation contract. Visual inspection and documentation are required for proof of proper installation conformance (See ANSI/TIA 606-A for administrative requirements such as labeling).

Performance test documentation of the installed cabling shall be provided to the building owner or agent per contract requirements, or, in lieu of contract requirements, in the format delivered by the certification test instrument. Certification of the

cabling in commercial buildings determines whether the cabling meets expected ANSI/TIA 568-B Series performance (e.g., category 5e, category 6). This TIA performance specification is used by application standards organizations to develop future applications and ease the cabling burden of consumers. Consumers can then take advantage of these advances in application technology for their networks.

Field testing of installed cabling shall be performed in accordance with Annex A.

This annex is normative and is considered part of this standard.

Annex A (Normative): Field Test Requirements

A.1 General

Transmission performance depends on cable characteristics, connecting hardware, patch cords and cross connect wiring, the total number of connections, and the care with which they are installed and maintained.

Field test instruments shall be calibrated and maintained at intervals specified by the manufacturer.

A.2 100 Ohm balanced UTP and ScTP Cabling

A.2.1 Test instruments

For field testing of the categories of cabling (e.g., categories 3, 5e and 6), test instruments shall meet or exceed the applicable requirements in ANSI/TIA 568-B.1 and

ANSI/TIA 568-B.2, including their addenda.

Commercially available certification test instruments specify their Level of performance attainment to ensure that the installed cabling meets the transmission characteristics found in ANSI/TIA 568-B.1 and ANSI/TIA 568-B.2, including their addenda.

A.2.2 Performance parameters

The field tests required for balanced twisted-pair cabling are specified in ANSI/TIA 568-B.1 and ANSI/TIA 568-B.2, including their addenda.

A.2.3 Permanent link test configuration

Installed cabling shall be certified in accordance with the permanent link test configuration (see Figure 23) unless specified to be tested as a channel.

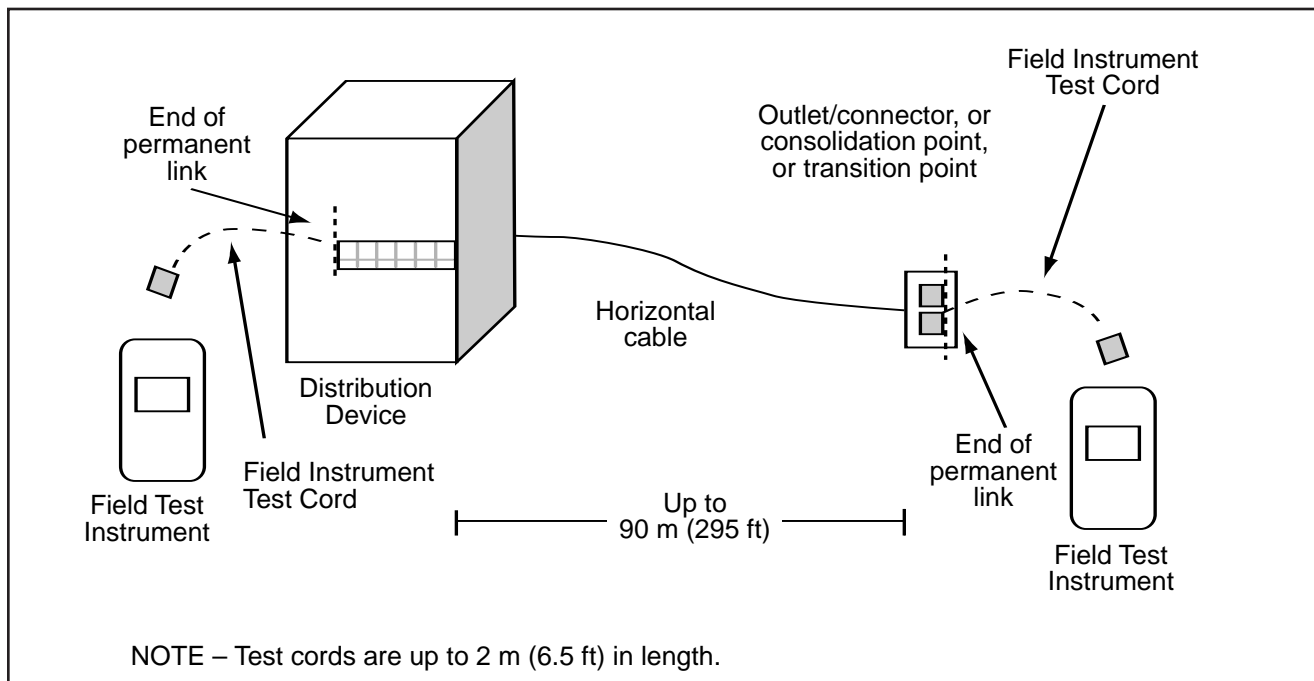

Figure 23—Permanent link test configuration

A.2.4 Channel test configuration

When a channel is specified for testing, it shall be certified in accordance with the channel test configuration (see Figure 24).

A.2.5 Backbone and other cabling test configuration

The wire map test for all pairs in backbone and other than horizontal cabling shall be performed and recorded for all segments. Wire map tests include:

- Continuity to the remote end
- Shorts between any two or more conductors
- Crossed pairs
- Reversed pairs
- Split pairs
- Any other miswiring

The length of each backbone cable segment should be measured and recorded.

A.3 Optical fiber cabling

TIA/TSB-140 describes the methods by which optical fiber cabling is to be tested. An optical fiber cabling link may consist of a fiber or concatenated fibers (spliced, cross-connected or interconnected) with a connector or adapter on each end. The fiber type, link length, the number and quality of terminations and splices, cable stresses, and wavelength can all affect attenuation measurements.

Testing conducted on optical fiber cabling should be in accordance with a published standard. As noted in TIA/TSB-140, testing installed optical fiber cabling for attenuation with an OLTS, as described in cabling standards, and verifying the cabling length and polarity constitutes Tier 1 testing. Tier 2 testing, which is optional, includes the Tier 1 tests plus the addition of an optical time domain reflectometer (OTDR) trace. An OTDR trace can be used to characterize the installed fiber link. These traces provide an indication of the uniformity of cable attenuation, and indicate events along the fiber link. These events may be characterized as insertion loss associated with severe bends in a cable run, connector insertion loss and splice insertion loss.

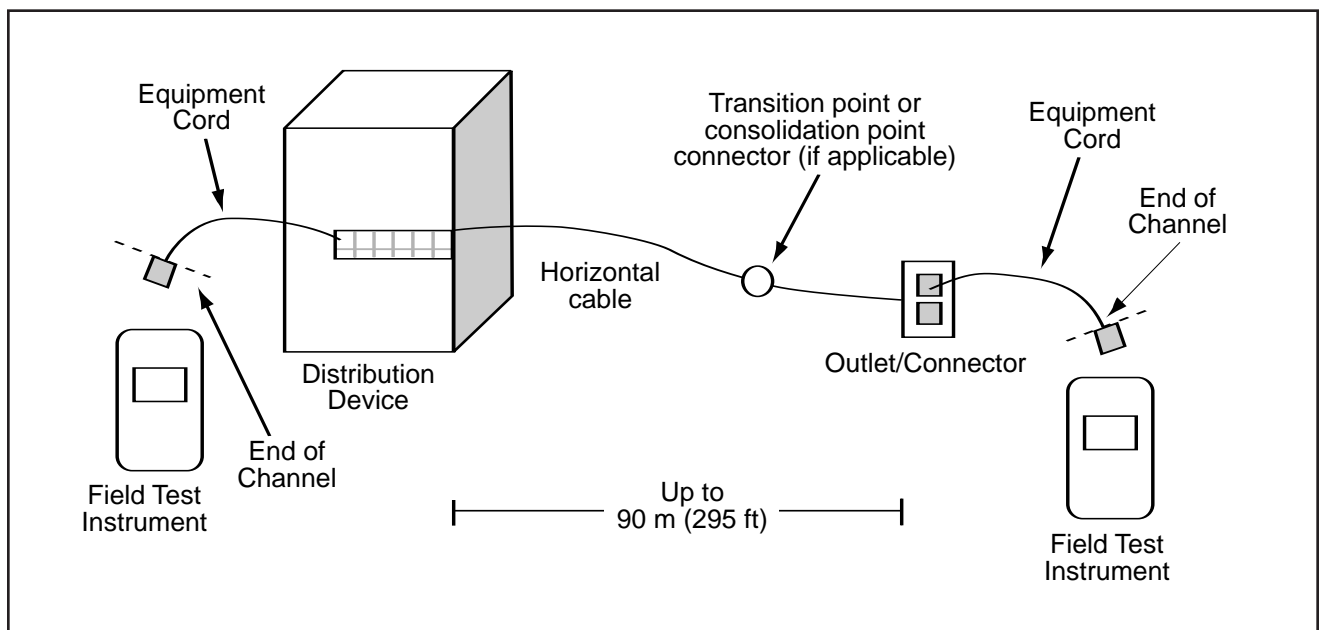

Figure 24—Channel test configuration

Tier 1 criteria, as specified in TIA/TSB-140, constitutes conformance testing in accordance with this standard. The attenuation measurement result, using the Tier 1 criteria, shall be less than the designed attenuation budget (also known as loss budget) that is based on the number of terminations and cable length.

A.3.1 Test instruments

OLTS field test instruments for multimode optical fiber shall meet the requirements as specified in ANSI/TIA 526-14-A. OLTS field test instruments for single-mode shall meet the requirements as specified in ANSI/TIA 526-7. Additionally, the light source is to meet the launch requirements of ANSI/TIA 455 78B. This launch condition can be achieved either within the field-test instrument by the manufacturer, or by use of an external mandrel wrap applied to the source test jumper with a Category 1 Coupled Power Ratio (CPR) light source.

NOTE—Refer to ANSI/TIA 526-14-A for details on measuring source CPR.

The mandrel-wrap is installed on the transmit test jumper of an OLTS having an overfilled launch when it is used to measure the link loss of multimode fiber links. The installation of the mandrel wrap is performed by wrapping a length of fiber around a smooth round mandrel (rod) for a total of five (5) non-overlapping wraps. A mandrel wrap is never installed on the receive test jumper (optical power meter). Table 6 shows mandrel diameters for typical cabled fiber types.

NOTE – The mandrel diameters are based on nominal values of 20 mm and 25 mm reduced by the cable diameter and rounded up.

A.3.2 Performance parameters

OLTS field tests required for optical fiber cabling are as follows:

- Length
- Polarity
- Attenuation

A.3.3 Cabling test configuration

ANSI/TIA 568-B.1 specifies the use of a one jumper reference as described in ANSI/TIA-14-A for multimode cabling and ANSI/TIA 526-7 for single-mode cabling. The following subclauses describe the process for testing multimode fiber cabling with a one jumper reference and the test jumper connected to the source having five non-overlapping wraps of multimode fiber on a mandrel. The procedure is also applicable to single-mode cabling, however, the five non-overlapping wraps of multimode fiber would be replaced with a single 30 mm (1.2 in) diameter loop of single-mode fiber.

A.3.3.1 Verifying test jumper quality

To verify that the test jumpers are in acceptable condition, first reference the light source to the optical power meter (*see Figure 25 on next page*). Disconnect test jumper (J1) from the power meter (only) and

Table 6. Acceptable mandrel diameters for common multimode cable types (five wraps)

Fiber Core/Cladding Size (µm)	Cable Type (Diameter)			
	900 µm Buffered Fiber (mm)	2.0 mm Jacketed Cable (mm)	2.4 mm Jacketed Cable (mm)	3.0 mm Jacketed Cable (mm)
50/125	25	23	23	22
62.5/125	20	18	18	17

insert a second test jumper (J2) by connecting it to the power meter and to (J1) with a mating adapter (see Figure 26) and record the measurement. Disconnect both ends of J2, interchange the ends, and reconnect it and record the measurement. The resulting measurements, P_{verify} , should be within the appropriate connector loss specification. For example, if the connector used is specified at 0.75 dB, the reading on the power meter should be within 0.75 dB of P_1 .

A.3.3.2 Steps to measure the cabling optical loss

The one jumper reference is used to measure the cabling optical loss. The test jumpers shall be 1 m (3.3 ft) to 5 m (16.4 ft) in length and shall be verified to ensure they are of acceptable quality. The basic steps taken to measure and calculate multimode cabling attenuation include:

- 1) Verifying test jumper quality (once before testing)
- 2) Setting the reference (once before testing)
- 3) Measuring link attenuation (each link)
- 4) Calculating link attenuation (each link)

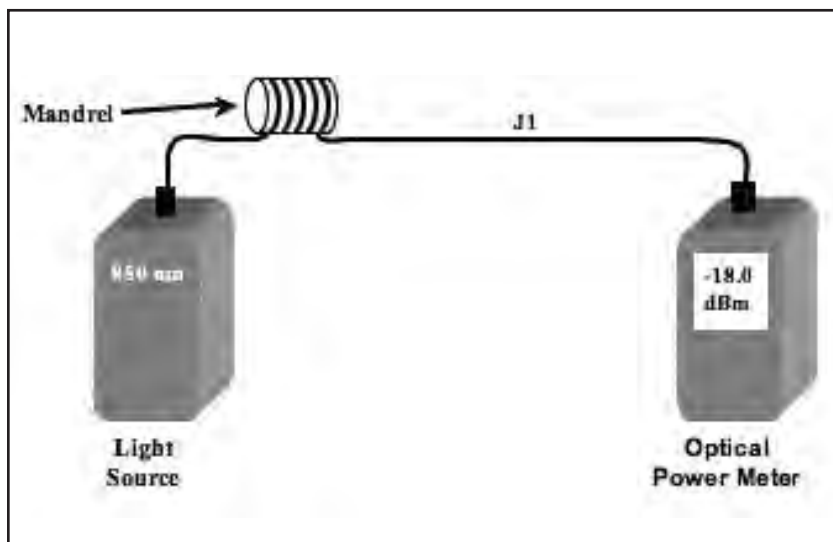

Figure 25—Example of OLTS reference measurement (P_1) with one test jumper (multimode)

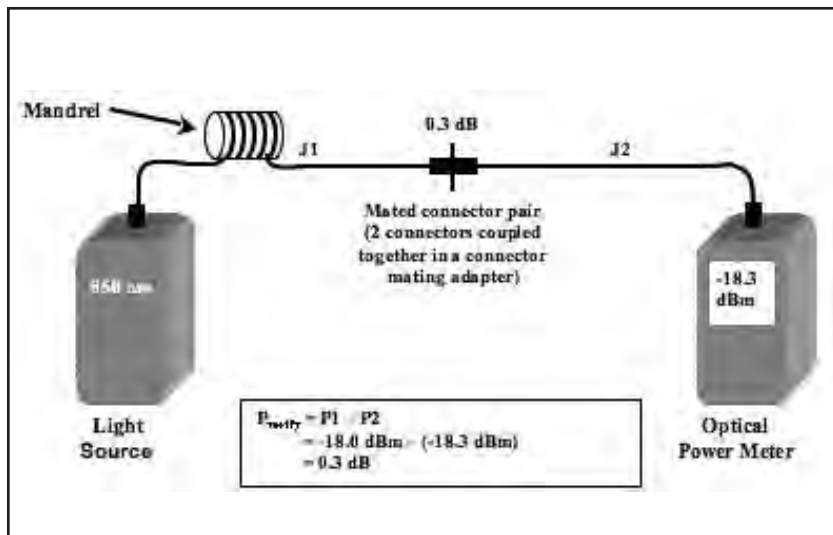

Figure 26—Example of a measurement (P_2) when verifying OLTS test jumpers (multimode)

A.3.3.3 Setting the reference

When referencing the light source to the power meter, one test jumper (J1) is to be connected between the light source and the power meter (see Figure 27 on next page) and a reference measurement taken (P_1 [dBm]).

NOTE – To improve the stability of the reference reading and for easier handling, it may be helpful to secure the mandrel to the light source by some means such as a cable tie or tape. Care should be taken to ensure that the fiber jacket is not deformed or damaged when using a cable tie or tape.

A.3.3.4 Measuring link attenuation

Connect the end of test jumper (J1) (source end) to one end of the link, and connect an acceptable test jumper (J2) between the other end of the link and the meter (see Figure 28 on next page). The optical power reading is P_2 (dBm).

A.3.3.5 Calculating link attenuation

Equation 1 is used to determine the fiber cabling link loss (attenuation).

$$\text{Attenuation (dB)} = P_1(\text{dBm}) - P_2(\text{dBm})$$

Equation 1

where:

P_1 = Reference power measurement

P_2 = Cabling test power measurement

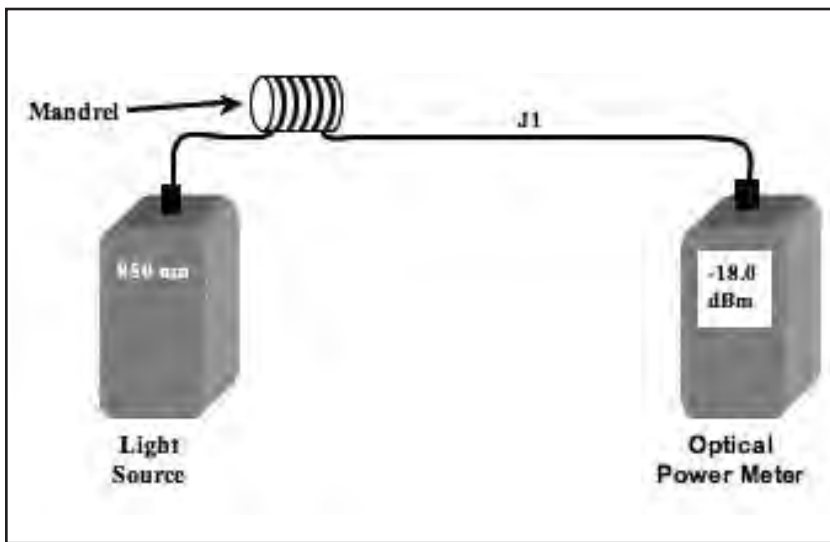

Figure 27—Example of OLTS reference measurement (P_1) with one test jumper (multimode)

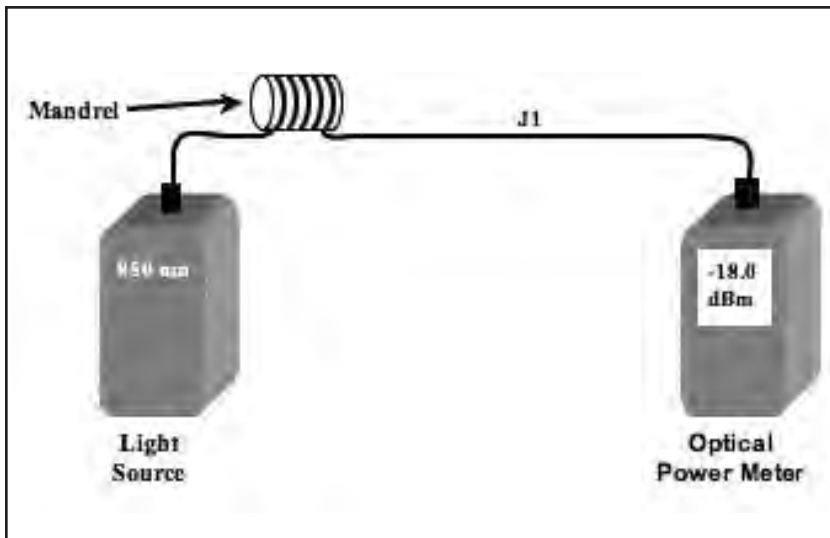

Figure 28—Example of a multimode link attenuation measurement (P_2)

(This annex is not part of this standard.)

Annex B (Informative): Bibliography and References

This annex contains information on the documents that are related to or have been referenced in this document. Many of the documents are in print and are distributed and maintained by national or international standards organizations. These documents can be obtained through contact with the associated standards body or designated representatives. The applicable electrical code in the United States is the NEC.

American National Standards Institute (ANSI)
25 West 43rd St., 4th Floor
New York, NY 10036
USA
(212) 642-4900
www.ansi.org

X3.166-1990, *ANSI Standard for Token Ring FDDI Physical Layer Medium Dependent (PMD)*

Z136.2-1997, *American Standard for the Safe Operation of Optical Fiber Communication Systems Utilizing Laser Diode and LED Sources*

American Society for Testing and Materials (ASTM)
100 Barr Harbor Drive
West Conshohocken, PA 19428-2959
USA
(610) 832-9585
www.astm.org

ASTM B539 2002, *Measuring Contact Resistance of Electrical Connections (Static Contacts)*

BICSI a Telecommunications Association
8610 Hidden River Parkway
Tampa, FL 33637-1000
USA
(800) 242-7405
www.bicsi.org

BICSI Telecommunications Distribution Methods Manual

BICSI Information Transport Systems Installation

BICSI Customer-owned Outside Plant Methods Manual

Telecommunications Industry Association (TIA)
2500 Wilson Blvd., Suite 300
Arlington, VA 22201-3836
USA
(703) 907-7700
www.tiaonline.org

ANSI/TIA 492AAAB-1998 (r2002), *Detail Specification for 50 μm Core Diameter/125 μm Cladding Diameter Class of Multimode, Graded-Index Optical Waveguide Fibers*

TIA 455-B-1998, *Standard Test Procedures for Fiber Optic Fibers, Cables and Transducers, Sensors, Connecting and Terminating Devices, and other Fiber Optic Components*

ANSI/TIA 492AAAA-A-1997 (r2002), *Detail Specification for 62.5 μm Core Diameter/125 μm Cladding Diameter Class Ia Graded-Index Multimode Optical Fibers*

ANSI/TIA 492CAAA-1998 (r2002), *Detail Specification for Class IVa Dispersion-Unshifted Single-mode Optical Fibers*

ANSI/TIA/EIA 526-7-2003, *OFSTP 7-Optical Power Loss Measurements of Installed Single-mode Fiber Cable Plant*

ANSI/TIA/EIA 526-14-A-1998 (r2003), *OFSTP 14-Optical Power Loss Measurements of Installed Multimode Fiber Cable Plant*

ANSI/TIA 568-B Series 2003, *Commercial Building Telecommunications Cabling Standard*

ANSI/TIA 598-B-2001, *Optical Fiber Cable Color Coding*

ANSI/TIA 604-3-A-2000, *FOCIS 3 Fiber Optic Interconnector Intermateability Standard*

ANSI/TIA 606-A, *Administration Standard for the Telecommunications Infrastructure of Commercial Buildings*

ANSI J-STD-607-A 2002, *Commercial Building Grounding and Bonding Requirements for Telecommunications*

ANSI/TIA-758 A 2004, *Customer-owned Outside Plant Telecommunications Cabling Standard*

ANSI/TIA-569-B-2004, *Commercial Building Standard for Telecommunications Pathways and Spaces*

TIA/TSB 31-B, FCC 47 CFR 68, *Rationale and Measurement Guidelines*

TIA/TSB-140, 2004; *Additional Guidelines for Field-Testing Length, Loss and Polarity of Optical Fiber Cabling Systems*

Federal Communications Commission (FCC)
445 12th Street SW
Washington, DC 20554
USA
(888) 225-5322
www.fcc.org

Federal Communications Commission (FCC) Washington D.C., “*The Code of Federal Regulations, FCC 47 CFR 68*”

Federal and Military Specifications
National Communications System (NCS)
Technology and Standards Division
701 South Court House Road
Arlington, VA 22204-2198
USA
(703) 607-6200
www.ncs.gov

FIPS PUB 174, *Commercial Building Telecommunications Wiring Standard*

Insulated Cable Engineers Association, Inc. (ICEA)
PO Box 1568
Carrolton, GA 30112
USA
(770) 830-0369
www.icea.net

ANSI/ICEA S-80-576-2002, *Category 1 & 2 Individually Unshielded Twisted Pair Indoor Cables for use in Communications Wiring Systems*

ANSI/ICEA S-83-596-2001, *Fiber Optic Premises Distribution Cable*

ICEA S-87-640-1999, *Fiber Optic Outside Plant Communications Cable*

International Electrotechnical Commission (IEC)
Sales Department
PO Box 131
3 rue de Varembe
1211 Geneva 20
Switzerland
+41 22 34 01 50
www.iec.ch

IEC 60603-7-1996, *Detail Specification for Connectors, 8 Way, Including Fixed and Free Connectors with Common Mating Features*

The Institute of Electrical and Electronic Engineers, Inc (IEEE)
IEEE Operations Center
445 Hoes Ln., PO Box 1331
Piscataway, NJ 08854-1331
USA
(732) 981-0060
www.ieee.org

ANSI/IEEE C2-2002, *National Electrical Safety Code*

ANSI/IEEE C62.11-2005, *Metal Oxide Surge Arrestors for AC Power Circuits*

IEEE 802.3-2005 (also known as ISO 8802-3:2003), Part 3: *Carrier Sense Multiple Access with Collision Detection (CSMA/CD) Access Method and Physical Layer Specifications*

IEEE 802.7-1989 (R1997) *IEEE Recommended Practices for Broadband Local Area Networks*

National Electrical Manufacturers Association (NEMA)
1300 N. 17th Street, Suite 1847
Rosslyn, VA 22209
USA
(703) 841-3200
www.nema.org

NEMA 250-2003, *Enclosures for Electrical Equipment (1000 Volts Maximum)*

National Fire Protection Association (NFPA)
Batterymarch Park
Quincy, MA 02269
USA
(617) 770-3000
www.nfpa.org

ANSI/NFPA 70-2005, *National Electrical Code*

ANSI/NFPA 75-2003; *Standard for the Protection of Information Technology Equipment*

NFPA/NESC-2002, *National Electrical Safety Code*

NFPA 101-2005, *Life Safety Code*

Society of Cable Telecommunications Engineers (SCTE)
140 Philips Rd.
Exton, PA 19341-1318
USA
(800) 542-5040
www.scte.org

ANSI/SCTE 74-2003, (formerly IPS SP 001), *Specification for 75-Ohm Braided Flexible RF Coaxial Drop Cable*

ANSI/SCTE 15-2001 (formerly IPS SP 100), *Specification for Trunk, Feeder and Distribution Coax Cable*

Telcordia (formerly BELLCORE)
Telcordia Corporate Headquarters
One Telcordia Drive
Piscataway, NJ 08854-4157
USA
(732) 699-2000
www.telcordia.com

Bellcore GR 1503 CORE, March 1995, *Bellcore Generic Requirements for Coaxial Connectors (Series 59, 6, 7 and 11)*

Underwriters Laboratories, Inc. (UL)
333 Pfingsten Road
Northbrook, IL 60062-2096
USA
(847) 272-8800
www.ul.com

UL 444/CSA C22.2 No. 214 02, *Communications Cables*

The organizations listed below can be contacted to obtain reference information.

Canadian Standards Association (CSA)
5060 Spectrum Way
Mississauga, Ontario
L4W 5N6 Canada
(800)-463-6727
www.csa.ca

Electronic Industries Alliance (EIA)
2500 Wilson Blvd., Suite 400
Arlington, VA 22201-3836
USA
(703) 907-7500
www.eia.org

IPC, Association Connecting Electronics Industries
3000 Lakeside Dr. 309 S
Bannockburn, IL 60015
USA
(847) 615-7100
www.ipc.org

International Organization for Standardization (ISO)
1, Rue de Varembe
Case Postale 56
CH-1211 Geneva 20
Switzerland
+41 22 749 01 11
www.iso.org

Current NEIS Published by NECA:

National Electrical Contractors Association
3 Bethesda Metro Center, Suite 1100
Bethesda, MD 20814
(301) 657-3110 tel
(301) 215-4500 fax
www.neca-neis.org

- NECA 1-2000, *Standard Practices for Good Workmanship in Electrical Contracting* (ANSI)
- NECA 90-2004, *Recommended Practice for Commissioning Building Electrical Systems* (ANSI)
- NECA 100-1999, *Symbols for Electrical Construction Drawings* (ANSI)
- NECA 101-2001, *Standard for Installing Steel Conduits (Rigid, IMC, EMT)*
- NECA 102-2004, *Standard for Installing Aluminum Rigid Metal Conduit* (ANSI)
- NECA/AA 104-2006, *Recommended Practice for Installing Aluminum Building Wire and Cable* (ANSI)
- NECA/NEMA 105-2002, *Recommended Practice for Installing Metal Cable Tray Systems* (ANSI)
- NECA 111-2003, *Standard for Installing Nonmetallic Raceways (RNC, ENT, LFNC)* (ANSI)
- NECA/NACMA 120-2006, *Standard for Installing Armored Cable (AC) and Metal-Clad Cable (MC)* (ANSI)
- NECA 200-2002, *Recommended Practice for Installing and Maintaining Temporary Electrical Power at Construction Sites* (ANSI)
- NECA 202-2001, *Recommended Practice for Installing and Maintaining Industrial Heat Tracing Systems* (ANSI)
- NECA 230-2003, *Standard for Selecting, Installing, and Maintaining Electric Motors and Motor Controllers* (ANSI)
- NECA/FOA 301-2004, *Standard for Installing and Testing Fiber Optic Cables* (ANSI)

- NECA 303-2005, *Standard for Installing Closed-Circuit Television (CCTV) Systems* (ANSI)
- NECA 305-2001, *Standard for Fire Alarm System Job Practices* (ANSI)
- NECA 331-2004, *Standard for Building and Service Entrance Grounding and Bonding*
- NECA 400-1998, *Standard for Installing and Maintaining Switchboards* (ANSI)
- NECA 402-2001, *Recommended Practice for Installing and Maintaining Motor Control Centers* (ANSI)
- NECA/EGSA 404-2000, *Recommended Practice for Installing Generator Sets* (ANSI)
- NECA 405-2001, *Recommended Practice for Installing and Commissioning Interconnected Generation Systems* (ANSI)
- NECA 406-2003, *Standard for Installing Residential Generator Sets* (ANSI)
- NECA 407-2002, *Recommended Practice for Installing and Maintaining Panelboards* (ANSI)
- NECA 408-2002, *Recommended Practice for Installing and Maintaining Busways* (ANSI)
- NECA 409-2002, *Recommended Practice for Installing and Maintaining Dry-Type Transformers* (ANSI)
- NECA 410-2005, *Standard for Installing and Maintaining Liquid-Filled Transformers* (ANSI)
- NECA/IESNA 500-1998, *Recommended Practice for Installing Indoor Commercial Lighting Systems* (ANSI)
- NECA/IESNA 501-2000, *Recommended Practice for Installing Exterior Lighting Systems* (ANSI)
- NECA/IESNA 502-1999, *Recommended Practice for Installing Industrial Lighting Systems* (ANSI)
- NECA 503-2005, *Standard for Installing Fiber Optic Lighting Systems*
- NECA/BICSI 568-2006, *Standard for Installing Commercial Building Telecommunications Cabling* (ANSI)
- NECA/MACSCB 600-2003, *Recommended Practice for Installing and Maintaining Medium-Voltage Cable* (ANSI)
- NECA/NEMA 605-2005, *Recommended Practice for Installing Underground Nonmetallic Utility Duct* (ANSI)

<This page intentionally left blank>



National Electrical
Contractors Association
3 Bethesda Metro Center
Suite 1100
Bethesda, MD 20814
301-657-3110
fax: 301-215-4500
www.neca-neis.org

Codes & Standards
Index: NECA 568 (R)
1.5K/6-06



NEIS